

Zypad BR2000

Wearable Computer

Rev 3 – Feb 2012 – 110125-20003, preliminary

Trademarks

All trademarks both marked and not marked appearing in this document are the property of their respective owners.

Document Revision History

REVISION	DESCRIPTION	DATE
3	Preliminary release	Feb 2012

Table of Contents

Trademarks	2
Document Revision History	2
Table of Contents	3
Important User Information	5
Safety Notices and Warnings	5
Life Support Policy	6
Warranty	6
CE Notice	6
WEEE	6
RoHS	6
Technical Assistance	7
Conventions	7
Product Overview	8
Features	9
Processor	9
Memory	9
Communications	9
Display and Audio	9
Power Supply	9
User Controls and Indicators	9
Mechanical	9
Related Documents	10
Hardware Reference	11
Processor	11
Memory	11
On-board Memory	11
Removable Storage	11
Battery-backed real-time clock	11
Communications	12
Wi-Fi	12
Bluetooth	13
GPS	13
Ethernet	14
USB	14
Serial Ports	14
Custom Expansion Port	15
Future Configuration	15
Display and Audio	15
Display	15
Headphone and Microphone	16
Configuration Control and Maintenance Display	16
Power Supply	16
Removable Battery Pack	16
Optional Internal Backup Battery	17

User Controls, Indicators, and Connectors	18
User Controls and Indicators.....	18
<i>Power On/Off Button</i>	18
<i>LED Status Indicators</i>	18
<i>Secure Erase Button (custom factory configuration)</i>	18
<i>Programmable Buttons</i>	18
Front Panel Connectors	19
<i>J1: USB, Serial, Power Input, and Remote On/Off</i>	19
<i>J2: Audio, VGA Display, and USB</i>	20
<i>J3: Ethernet, Serial, and Power Output</i>	21
Mechanical Specifications	22
Enclosure	22
Mounting Options	22
<i>Wearable</i>	22
<i>Vehicle-mounted</i>	22
System Specification.....	23
Processor	23
Power Supply	23
Display and Audio	23
Mechanical	24
Environmental	24
EMI/EMC.....	24
Appendix A – Revision History	25
Appendix B – Development System	26
Battery Charger	26
<i>Status Indicators</i>	26
Starter Cable Set.....	27
<i>Cable 1: USB, Serial, Power Input, and Remote On/Off</i>	27
<i>Cable 2: Audio, VGA Display, and USB</i>	29
<i>Cable 3: Ethernet, Serial, and Power Output</i>	31
Eurotech Worldwide Presence	32

Important User Information

In order to lower the risk of personal injury, electric shock, fire, or equipment damage, users must observe the following precautions as well as good technical judgment, whenever this product is installed or used.

All reasonable efforts have been made to ensure the accuracy of this document; however, Eurotech assumes no liability resulting from any error/omission in this document or from the use of the information contained herein.

Eurotech reserves the right to revise this document and to change its contents at any time without obligation to notify any person of such revision or changes.

Safety Notices and Warnings

The following general safety precautions must be observed during all phases of operation, service, and repair of this equipment. Failure to comply with these precautions or with specific warnings elsewhere in this manual violates safety standards of design, manufacture, and intended use of the equipment. Eurotech assumes no liability for the customer's failure to comply with these requirements.

The safety precautions listed below represent warnings of certain dangers of which Eurotech is aware. You, as the user of the product, should follow these warnings and all other safety precautions necessary for the safe operation of the equipment in your operating environment.

Installation in Enclosures

In the event that the product is placed within an enclosure, together with other heat generating equipment, ensure proper ventilation.

Do Not Operate in an Explosive Atmosphere

Do not operate the equipment in the presence of flammable gases or fumes. Operation of any electrical equipment in such an environment constitutes a definite safety hazard.

Alerts that can be found throughout this manual

The following alerts are used within this manual and indicate potentially dangerous situations.



Danger, electrical shock hazard:

Information regarding potential electrical shock hazards:

- Personal injury or death could occur. Also damage to the system, connected peripheral devices, or software could occur if the warnings are not carefully followed.
 - Appropriate safety precautions should always be used, these should meet the requirements set out for the environment that the equipment will be deployed in.
-



Warning:

Information regarding potential hazards:

- Personal injury or death could occur. Also damage to the system, connected peripheral devices, or software could occur if the warnings are not carefully followed.
 - Appropriate safety precautions should always be used, these should meet the requirements set out for the environment that the equipment will be deployed in.
-



Information and/or Notes:

These will highlight important features or instructions that should be observed.

Use an Appropriate Power Supply

- Only start the product with a power supply that conforms to the voltage requirements as specified in [Power Supply](#), page 23. In case of uncertainty about the required power supply, please contact your local Eurotech Technical Support Team.
- The removable battery pack is UL and UN/DOT approved.
- Use certified power cables. The power cable must fit the product, the voltage, and the required current. Position cable with care. Avoid positioning cables in places where they may be trampled on or compressed by objects placed on it. Take particular care of the plug, power-point, and outlet of power cable.
- Avoid overcharging power-points.

Use Antistatic Precautions

To avoid damage caused by ESD (Electro Static Discharge), always use appropriate antistatic precautions when handling any electronic equipment.

Life Support Policy

Eurotech products are not authorized for use as critical components in life support devices or systems without the express written approval of Eurotech.

Warranty

For Warranty terms and conditions users should contact their local Eurotech Sales Office. See [Eurotech Worldwide Presence](#), page 32 for full contact details.

CE Notice

The product described in this manual is marked with the  label in accordance with the 1999/5/EC regulation. Eurotech shall not be liable for use of its products with equipment (i.e. power supplies, personal computers, etc.) that are not CE marked.

WEEE

The information below is issued in compliance with the regulations as set out in the 2002/96/EC directive, subsequently superseded by 2003/108/EC. It refers to electrical and electronic equipment and the waste management of such products. When disposing of a device, including all of its components, subassemblies, and materials that are an integral part of the product, you should consider the WEEE directive.

This device is marketed after August 13, 2005 and you must separate all of its components when possible and dispose of them in accordance with local waste disposal legislations.

- Because of the substances present in the equipment, improper use or disposal of the refuse can cause damage to human health and to the environment.
- With reference to WEEE, it is compulsory not to dispose of the equipment with normal urban refuse and arrangements should be instigated for separate collection and disposal.
- Contact your local waste collection body for more detailed recycling information.
- In case of illicit disposal, sanctions will be levied on transgressors.

RoHS

This device, including all its components, subassemblies and the consumable materials that are an integral part of the product, has been manufactured in compliance with the European directive 2002/95/EC known as the RoHS directive (Restrictions on the use of certain Hazardous Substances). This directive targets the reduction of certain hazardous substances previously used in electrical and electronic equipment (EEE).

Technical Assistance

If you have any technical questions, cannot isolate a problem with your device, or have any enquiry about repair and returns policies, contact your local Eurotech Technical Support Team.

See [Eurotech Worldwide Presence](#), page 32 for full contact details.

Transportation

When transporting any device or system, for any reason, it should be packed using anti-static material and placed in a sturdy box with enough packing material to adequately cushion it.



Warning:

Any product returned to Eurotech that is damaged due to inappropriate packaging will not be covered by the warranty.

Conventions

The following table describes the conventions for signal names used in this document.

Convention	Explanation
GND	Digital ground plane
#	Active low signal
_P	Positive signal in differential pair
_N	Negative signal in differential pair

The following table describes the abbreviations for direction and electrical characteristics of a signal used in this document.

Type	Explanation
I	Signal is an input to the system
O	Signal is an output from the system
IO	Signal may be input or output
P	Power and ground
A	Analog signal
OD	Open-drain
CMOS	3.3 V CMOS
LVC MOS	1.05 V CMOS
LV TTL	Low Voltage TTL
3.3	3.3 V signal level
5	5 V signal level
USB	USB 2.0 signal
LVDS	Low Voltage Differential Signalling
PCIe	PCI Express signal, not 3.3 V tolerant
SATA	SATA differential signal
NC	No Connection
Reserved	Use is reserved to Eurotech

Product Overview

The Zypad BR2000 is a rugged, small-form factor, wearable computer and vehicle server providing high-performance, versatile computing solutions for civil and military applications. Featuring low-power, high-performance processing, high-speed wired and wireless capabilities, and built-in GPS tracking, this adaptable computer serves as an ideal tool for industrial and mining, transportation, emergency search and rescue, healthcare, and military applications. Full graphical display for high-resolution output and extensible peripheral I/O are available using push-pull circular, IP67-rated connectors. A small LCD-based user interface is also provided for configuration and maintenance functions.

With the Zypad BR2000, you can quickly and easily create a rugged computing system, loaded with your application software, which precisely meets your requirements. The system is compatible with the Windows® Embedded Standard, Windows 7, and Wind River Linux operating systems. Software support includes Eurotech's application programming interfaces for handling tasks specifically related to the Zypad BR2000 feature set and Eurotech's Everyware™ Software Framework.

The following diagram of the Zypad BR2000 is for illustrative purposes only. Actual units may vary in appearance.



Figure 1. Zypad BR2000

Eurotech offers a development system allowing you to quickly become familiar with the Zypad BR2000 functionality prior to customization for your specific application. In addition to the Zypad BR2000, this system includes two CompactFlash cards loaded with Windows® Embedded Standard and Wind River Linux, a Lithium-Ion battery pack, AC power adapter, battery charger with AC power adapter, starter cable set, and DVD with documentation. For details about this development system, see [Appendix B](#), page 26.

Features

Processor

- Intel® Atom™ processor E660T at 1.3 GHz
- Intel® Platform Controller Hub EG20T
- Trusted Platform Management (optional)

Memory

- Up to 2 GB on-board RAM and up to 32 GB on-board eMMC flash SSD
- CompactFlash card slot supporting optional Secure Erase function (Zeroization)
- Battery-backed real-time clock

Communications

- 802.11 b/g/n Wi-Fi with integrated antenna
- Bluetooth with integrated antenna
- Support for external cellular modem (Contact Eurotech for availability.)
- GPS receiver with integrated antenna
- Gigabit Ethernet
- Six USB 2.0 host ports
- Three serial ports
 - One EIA-232/485 port (8-wire)
 - Two EIA-232 ports (3-wire)
- Custom expansion port (USB, PCI Express, Digital I/O, SATA, and EIA-232/485)

Display and Audio

- 2D/3D display output
 - VGA (standard)
 - Custom configurations such as composite video and LVDS
- OLED graphics display for configuration control and maintenance
- Microphone input
- Headphone output

Power Supply

- Removable, rechargeable Lithium-Ion battery pack or external DC power input
- Option to support external Smart Battery
- Internal non-removable backup battery (Contact Eurotech for availability.)
- Auxiliary power outputs

User Controls and Indicators

- Power on/off button
- Remote power on/off control signal
- Concealed button supporting optional Secure Erase function (Zeroization)
- Two LED status indicators (System Power, Internal Battery Charger)
- Four programmable buttons

Mechanical

- Ruggedized, wearable enclosure
- Vehicle mounting plate option

Related Documents

This manual describes the Zypad BR2000 at the system level and is intended for system integrators. The following documents are also important resources for the Zypad BR2000.

Document	
Zypad BR2000 Quick Start	110125-2001

Table 1. Related Documents

Check the Eurotech support site (<http://support.eurotech-inc.com/>) for errata reports and for the latest release of the Zypad BR2000 documents.

Hardware Reference

This section gives an overview of the hardware features of the Zypad BR2000 including processor, memory, communications, display, audio, and power supply.

Processor

The Zypad BR2000 bases its architecture on an integrated two-chip solution comprised of the Intel® Atom™ processor E660T and Intel® Platform Controller Hub (Intel® PCH EG20T). The Intel Atom processor contains an integrated 2D/3D graphics engine supporting hardware-accelerated graphics display and video processing capabilities, while the Intel PCH EG20T supports extensive I/O and data storage capabilities. The processor architecture also fully integrates system functions that include system management and control implemented by an advanced chip level solution, tightly integrated power management controls, system BIOS firmware memory, and optional Trusted Platform Management (TPM) for industry-standard secure data encryption. For performance specifications, see [Processor](#) page 23.

Memory

On-board Memory

Double Data Rate Synchronous DRAM (DDR-2) is used for system main memory and frame buffer memory. Standard units include 1 GB with options available up to 2 GB. The Zypad BR2000 also includes an on-board eMMC flash SSD for expanded system storage. Standard units include 16 GB with options available up to 32 GB.

Removable Storage

The Zypad BR2000 includes a CompactFlash slot located behind a removable panel on the side of the enclosure. This slot supports high-capacity CompactFlash (CF) cards conforming to the CompactFlash standard for Type I and II cards operating at 3.3 V. Details about this standard are available at www.compactflash.org. In addition to providing mass storage, the Zypad BR2000 boots to the operating system from the CF card.

The following diagram shows the location of the CompactFlash slot.



Figure 2. CompactFlash Slot



Notes:

The removable panel is secured using two M2 X 4mm socket head cap screws.

As a custom factory configuration, the Zypad BR2000 supports secure erase of this storage device. Contact Eurotech for availability of this feature.

Battery-backed real-time clock

A real-time clock (RTC) function, included on the Zypad BR2000, retains the system date and time when the system is powered down. Accuracy is +/-55 seconds per month (@ 25°C). The unit includes a non-field replaceable, long-life battery to supply backup power for the RTC. The RTC battery will last 50 days without external power being applied or powered on with removable battery installed.

Communications

A key capability of the Zypad BR2000 is its extensive communication interfaces. Wi-Fi, Bluetooth, GPS, Ethernet, USB, serial, and custom expansion capabilities can be flexibly configured to meet different application requirements.

The following diagram shows the location of these interfaces.

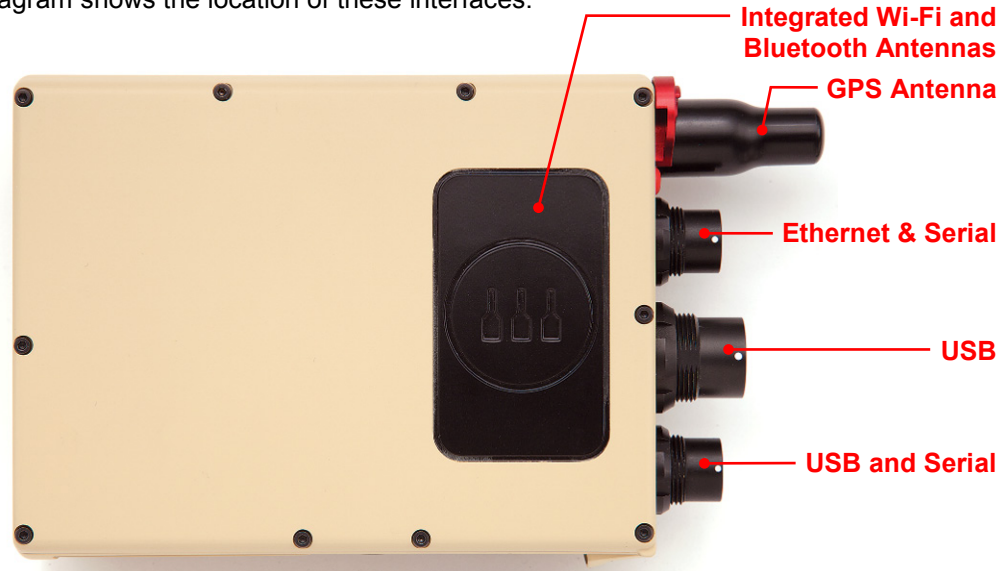

Figure 3. Communications

Wi-Fi

For connection to a Wi-Fi network, the Zypad BR2000 includes a Redpine Signals RS9110-N-11-02 module. This built-in module provides a fully integrated IEEE 802.11b/g/n Wi-Fi client device including integrated antenna for ultra-low power, handheld applications.

The following table summarizes the features of the RS9110 Wi-Fi module.

Feature	Description
Network Standard Support	IEEE 802.11b/g/h/i, draft 802.11 n/k
Data Rates	802.11n: 6.5, 13, 19.5, 26, 39, 52, 58.5, 65 Mbps 802.11g: 6, 9, 12, 18, 24, 36, 48, 54 Mbps 802.11b: 1, 2, 5.5, 11 Mbps
Frequency Band	2.412 - 2.484 GHz
Modulation Techniques	OFDM with BPSK, QPSK, 16-QAM, and 64-QAM 802.11b with CCK and DSSS
QoS	WMM and WMM Power Save Support
Wireless Security	802.11i: AES, TKIP, WEP, WPA, and WPA2
802.11n Features	MCS 0-7, STBC, RIFS, Greenfield Protection, A-MPDU, A-MSDU Aggregation with Block-ack, PSMP, MTBA
Certifications	802.11n Draft 2.0 WPA, WPA2, WMM, WMM Power-save, WPS, Voice-Personal

Note:

1. Specifications per the RS9110-N-11-02 Product Brief, www.redpinesignals.com.

Table 2. Wi-Fi Module Capabilities



Notes:

Wi-Fi and Bluetooth both use the 2.4GHz frequency band and may interfere with each other when used concurrently. Contact factory for availability of Wi-Fi/ Bluetooth coexistence solution to allow concurrent use of Wi-Fi and Bluetooth.

Bluetooth

The Zypad BR2000 includes a BlueGiga WT11 Bluetooth module with integrated antenna supporting connections to various Bluetooth devices. A typical application is a wireless headset. By default, Bluetooth is disabled.

The following table summarizes the features of the WT11 Bluetooth module.

Feature	Description
Network Standard Support	Class 1 Bluetooth module (range up to 200 meters) <ul style="list-style-type: none"> Nominal output power +15 dBm Nominal sensitivity -82 dB Uses 2.4 GHz ISM band Adaptive Frequency Hopping (AFH)
Enhanced Data Rate	Up to 3 Mbps
Supported Bluetooth Profiles	SPP, DUN, OBEX OPP, HFP v.1.5, DID, HID + HCI
Firmware Support	iWRAP™ command interface supports simple ASCII commands
Certifications	Bluetooth 2.1 + EDR CE, FCC, and IC

Note:

2. Specifications per the WT11 Bluetooth Module Product Brief, 14/10/09, www.bluegiga.com.

Table 3. Bluetooth Module Features



Notes:

Wi-Fi and Bluetooth both use the 2.4GHz frequency band and may interfere with each other when used concurrently. Contact factory for availability of Wi-Fi/ Bluetooth coexistence solution to allow concurrent use of Wi-Fi and Bluetooth.

GPS

The Zypad BR2000 includes a u-blox AMY-5M integrated GPS receiver and external antenna supporting navigation applications and allowing users to geographically reference the data sent over a wireless network. This module is based on the high-performance u-blox 5 positioning engine.

The following table summarizes the performance of the u-blox Amy-5M receiver.

Parameter	Description
Receiver Type	
Channels:	50
Frequency:	L1
Signals:	GPS C/A Code
Configuration	
Time pulse:	f = 0.25 ... 999 Hz (Tp = 1/f – 1ms)
Navigation update rate:	Up to 4Hz
Time-To-First-Fix (all satellites at -130 dBm)	
Cold Start (Autonomous):	36 s
Warm Start (Autonomous):	36 s
Hot Start (Autonomous):	<1 s
Aided Starts:	4 s (Dependent on aiding data connection speed and latency)
Sensitivity	
Tracking & Navigation:	-159 dBm
Reacquisition:	-159 dBm
Cold Start (Autonomous):	-141 dBm
Accuracy	
Horizontal position:	(CEP, 50%, 24 hours static, -130dBm, SEP: <3.5m) < 2.5 m Autonomous < 2.0 m SBAS
Timepulse signal:	30 ns RMS <60 ns 99%
Velocity(50% @ 30 m/s):	0.1 m/s
Heading:	0.5 degrees

Note:

3. Specifications per the AMY-5M Data Sheet, GPS.G5-MS5-08196-A3, www.u-blox.com.

Table 4. GPS Receiver Performance

Ethernet

For network connectivity, the Zypad BR2000 provides an Ethernet connection that provides the following capabilities:

- Compliant with the 1 Gb/s IEEE 802.3 802.3u 802.3ab Specifications
- IEEE 802.3ab auto negotiation support
- Full duplex operation at 10/100/1000 Mb/s
- Half duplex at 10/100 Mb/s
- Auto MDI, MDI-X crossover at all speeds

This connection is on [J3](#), page [21](#). Use CAT5e or better twisted pair cable (100 Ω , +/-15%) to connect the Zypad BR2000 to your Ethernet network.

USB

The Zypad BR2000 provides six Universal Serial Bus (USB) host port signal pairs on [J1](#), page [19](#) and [J2](#), page [20](#). These ports individually support the USB 2.0 specification operating at up to low (1.5 Mbps), full (12 Mbps), and high speed (480 Mbps). Aggregate total bandwidth may be affected by overall system loading.

To create a full-functioning USB host port, use the auxiliary power outputs (J1_+5V and J2_+5V) to supply the 5 V power required by client devices. Use cable that conforms to the USB 2.0 specification to connect the USB signal pairs to your client device. Per this specification, the cable must consist of one twisted data pair (28 AWG) and one non-twisted power pair (28 to 20 AWG) with an inner shield (aluminium metalized polyester), stranded tinned copper drain wire (28 AWG), outer shield ($\geq 65\%$ interwoven tinned copper braid), and PVC outer jacket. Ensure that the drain wire is grounded correctly based on your specific system-level cabling. Additional details about the USB specifications are available at www.usb.org.

Serial Ports

The Zypad BR2000 provides three EIA-232 serial ports. One serial port is a full-function UART, supplying the full complement of modem control signals, while the remaining two serial ports provide receive and transmit signals only. The following table describes the serial ports.

Connector	Serial Port	Description
J3	1	8-wire (note 4)
J1	2	3-wire
J1	3	3-wire

Note:

4. As a custom factory configuration, SP 1 can be configured for EIA-485. Contact Eurotech for details.

Table 5. Serial Ports

Custom Expansion Port

The Zypad BR2000 provides a custom expansion port located behind a removable panel on the rear of the enclosure. This expansion port can be customized for your specific application to provide additional I/O capabilities. The following are some example interfaces that can be provided by the expansion port:

- USB 2.0
- PCI Express
- SATA
- EIA-232/485
- Digital I/O
- Reset power button
- Maintenance serial port
- DC power in / DC power out
- System reset

Contact your Eurotech representative to discuss any customizations that your application requires.

Future Configuration

As a future configuration, the Zypad BR2000 will support an external cellular modem (CDMA, GSM, UMTS). For details about availability of this configuration, contact your local Eurotech representative.

Display and Audio

The Zypad BR2000 is designed to interface with a VGA display or helmet monocular, headphone, and microphone. The display can be wrist-worn, vest-mounted, hand-held, or hard-mounted. A small LCD-based user interface is also provided for configuration and maintenance functions.

The following diagram illustrates the location of the display and audio interfaces.



Figure 4. Display and Audio

Display

The Zypad BR2000 drives a VGA display on [J2](#), [page 20](#) with resolutions up to SVGA. This output provides red, green, and blue data, as well as horizontal sync and vertical sync signals. Use a controlled impedance video cable to connect the Zypad BR2000 to your display. Cables should not introduce major impedance discontinuities that cause signal reflections. In addition, connector J2 includes a Display Data Channel (DDC) serial interface for monitor Plug and Play capability with various computer displays. For electrical specifications, see [Display and Audio](#), [page 23](#).

As a custom factory configuration, the Zypad BR2000 can provide a composite video (NTSC/PAL) or LVDS display output in place of the VGA display output. For details about other custom display outputs, contact your local Eurotech representative.

Headphone and Microphone

For its audio interface, the Zypad BR2000 includes a stereo headphone output and stereo microphone input on [J2](#), page 20. Use standard speaker cable to connect the Zypad BR2000 to your headphones and microphone. For electrical specifications, see [Display and Audio](#), page 23.

Configuration Control and Maintenance Display

The Zypad BR2000 includes a small OLED graphics display located on the side of the enclosure. This display is controlled by your application providing information for functions such as configuration control and maintenance.

Power Supply

To support a variety of usage scenarios, the Zypad BR2000 accepts input power from a removable, rechargeable battery pack or an external power source connected to [J1](#), page 19. For power specifications, see [Power Supply](#), page 23. The following diagram illustrates the power supply architecture.

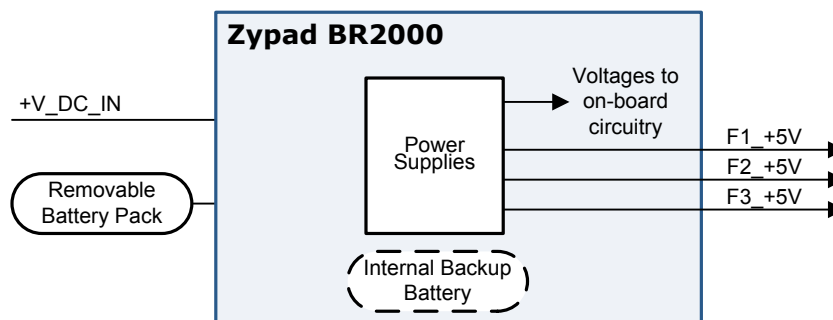

Figure 5. Power Supply Architecture

As custom factory configurations, the Zypad BR2000 can support an external Smart Battery or DC input and DC output from the custom expansion port. Contact Eurotech for details.

Removable Battery Pack

The removable battery pack holds disposable or rechargeable Lithium-Ion batteries. The Internal Battery Charger LED, located under the access panel on the side of the enclosure, indicates the status of the battery charger. The following diagram shows the location of the battery pack.



Figure 6. Battery Pack

Installation and Removal

To remove the battery pack, pull the battery latch from its seated position, twist the battery latch clockwise to unlock, and pull the battery pack out of the enclosure.



Figure 7. Battery Latch Unlocked Position

To install the battery pack, insert the battery pack into the opening in the enclosure, slide the battery pack into position until fully seated, twist the battery latch counter-clockwise to lock, and snap latch into its seated position.



Figure 8. Battery Latch Locked Position

Charging

The removable battery pack is charged using one of the following methods:

Method	Charging Time (Max Hours)
External battery charger	(note 6)
Zypad BR2000 connected to external power source (note 5)	(note 6)

Note:

- 5. The Zypad BR2000 must be turned off while charging.
- 6. Contact factory for charging times.

Table 6. Battery Pack Charging

Optional Internal Backup Battery

An optional internal, non-removable, rechargeable backup battery may be included with the Zypad BR2000 providing hot swap capability for the removable battery pack. When the battery pack reaches a low-power state, the Zypad BR2000 transitions into sleep mode. The backup battery provides power to the unit during the swapping of the removable battery pack. Once the battery pack has been replaced, the unit returns to full operational state.

Charging the Internal Backup Battery

To charge the internal backup battery, connect the Zypad BR2000 to an external power source. The removable battery pack does not charge the internal backup battery.

User Controls, Indicators, and Connectors

This section describes the user controls, indicators, and connectors on the Zypad BR2000.

User Controls and Indicators

The following diagram illustrates the location of the user controls and indicators on the Zypad BR2000.



Figure 9. Zypad BR2000 User Controls and Indicators

Power On/Off Button

The following table defines the functionality of the power on/off button. This button also connects to the remote power control signal, BTN_ONOFF# (J1 pin 4).

Power On/Off Button	Operation
Momentary assertion (greater than 2, less than 4 seconds)	From shutdown, initiates a power-up sequence to full operation. From full operation, initiates an orderly shutdown sequence and turns off power.
Continuous assertion (greater than 4 seconds)	Initiates a “4 second over-ride” and turns off power without notification to the operating system.

Table 7. Power On/Off Button

When the system is in Sleep mode (S3), a momentary press of the Power On/Off Button will return the system to normal operation.

LED Status Indicators

The Zypad BR2000 provides two light-emitting diodes (LEDs), located behind an access panel on the side of the enclosure, to indicate system operation. The following table describes these LEDs.

LED	Color	Description
Internal Battery Charger	Magenta	Blinking indicates charging
	Red	On indicates an error condition
	Green	On indicates battery is fully charged
System Power	Green	On indicates power is on
	Blue	On indicates external power is applied but not powered on (Notice that the LED will not be lit when using the battery pack.)

Table 8. LED Indicators

Secure Erase Button (custom factory configuration)

As a custom factory configuration, the Zypad BR2000 supports a zeroization function by pressing the Secure Erase Button for greater than four seconds. This button is located under a red swivel cover on the front of the enclosure. Standard units include the button on the enclosure; however, they do not support this zeroization function.

Programmable Buttons

The Zypad BR2000 includes four programmable buttons that can be customized for your specific application. An example application is UP, DOWN, SELECT, and BACK. These buttons are located on the side of the enclosure.

Front Panel Connectors

This section describes the electrical signals available on the connectors of the Zypad BR2000. Each section provides relevant details about the connector including part numbers, mating connectors, and signal descriptions. All electrical signals include ESD protection, and connector shields are tied to chassis ground and electrical ground. The following diagram illustrates the location of the connectors.



Figure 10. Front Panel Connectors

J1: USB, Serial, Power Input, and Remote On/Off

Connector: 19-pin, MIL-performance, push-pull circular, single-hand blind-mate receptacle, Fischer AL1211-DBPLU-104-A092PB12-12G13
 Mating plug: Fischer AL1211-SS-104-A092SR12

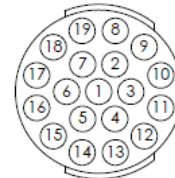

Connector J3 includes three USB 2.0 host ports, two EIA-232 serial ports (3-wire), an input for an external +12V DC power supply, and a remote power on/off control signal.

Pin	Name	Type	Description
1	J1_+5V	PO	+5V DC power output (software-controlled)
2	GND	P	Ground
3	GND	P	Ground
4	BTN_ONOFF#	IO-3.3	Remote power on/off control (see Power On/Off Button)
5	GND	P	Ground
6	GND	P	Ground
7	GND	P	Ground
8	RS232_B_TX	O	SP 2 (EIA-232), Transmit Data
9	RS232_B_RX	I	SP 2 (EIA-232), Receive Data
10	RS232_C_TX	O	SP 3 (EIA-232), Transmit Data
11	RS232_C_RX	I	SP 3 (EIA-232), Receive Data
12	USB_HOST6_P	IO-USB	USB 6
13	USB_HOST6_N		
14	USB_HOST5_P	IO-USB	USB 5
15	USB_HOST5_N		
16	USB_HOST4_P	IO-USB	USB 4
17	USB_HOST4_N		
18	GND	P	Ground
19	+V_DC_IN	PI	+12V DC power input

J2: Audio, VGA Display, and USB

Connector: 27-pin, MIL-performance, push-pull circular, single-hand blind-mate receptacle, Fischer AL1231-DBPLU-105-A102PB11-12G13

Mating plug: Fischer AL1231-SS-105-A102SR

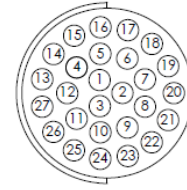

Connector J2 includes a microphone input, headphone output, VGA display output with DDC I²C bus, and three USB 2.0 host ports.

Pin	Name	Type	Description
1	J2_+5V	PO	+5V DC power output (software-controlled)
2	GND	P	Ground
3	GND	P	Ground
4	GND	P	Ground
5	GND	P	Ground
6	CBVS_VIDEO	AO	Composite video output (custom configuration)
7	MIC_IN_L	AI	Microphone input, Left channel
8	MIC_IN_R	AI	Microphone input, Right channel
9	HP_OUT_L	AO	Headphone output, Left channel
10	HP_OUT_R	AO	Headphone output, Right channel
11	DDC_SDA	IO	VGA display, DDC I ² C data
12	DDC_SCL	O	VGA display, DDC I ² C clock
13	USB_HOST1_P	IO-USB	USB 1
14	USB_HOST1_N		
15	RED_OUT	AO	VGA display, Red data
16	GND	P	Ground (Red data shield)
17	BLUE_OUT	AO	VGA display, Blue data
18	GND	P	Ground (Blue data shield)
19	VSYNC_OUT	AO	VGA display, Vertical sync
20	GND	P	Ground (Green data shield)
21	USB_HOST2_P	IO-USB	USB 2
22	USB_HOST2_N		
23	GREEN_OUT	AO	VGA display, Green data
24	HSYNC_OUT	AO	VGA display, Horizontal sync
25	USB_HOST3_P	IO-USB	USB 3
26	USB_HOST3_N		
27	GND	P	Ground

J3: Ethernet, Serial, and Power Output

Connector: 19-pin, MIL-performance, push-pull circular, single-hand blind-mate receptacle
 Fischer AL1211-DBPLU-104-A092PB11-12G13
 Mating plug: Fischer AL1211-SS-104-A092SR11

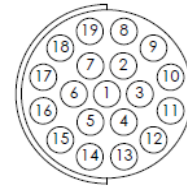

Connector J3 includes an Ethernet interface, a full-function EIA-232 serial port (8-wire), and +5V DC power output.

Pin	Name	Type	Description
1	J3_+5V	PO	+5V DC power output (software-controlled)
2	GND	P	Ground
3	RS232_A_CD	I	SP 1 (EIA-232), Carrier Detect
4	RS232_A_RX	I	SP 1 (EIA-232), Receive Data
5	GND	P	Ground
6	RS232_A_DSR	I	SP 1 (EIA-232), Data Set Ready
7	GND	P	Ground
8	MIDI0_T_P	IO-A	Ethernet, Channel 0
9	MIDI0_T_N		
10	MIDI1_T_P	IO-A	Ethernet, Channel 1
11	MIDI1_T_N		
12	MIDI2_T_P	IO-A	Ethernet, Channel 2
13	MIDI2_T_N		
14	MIDI3_T_P	IO-A	Ethernet, Channel 3
15	MIDI3_T_N		
16	RS232_A_DTR	O	SP 1 (EIA-232), Data Terminal Ready
17	RS232_A_TX	O	SP 1 (EIA-232), Transmit Data
18	RS232_A_RTS	O	SP 1 (EIA-232), Request To Send
19	RS232_A_CTS	I	SP 1 (EIA-232), Clear To Send

Mechanical Specifications

The mechanical design of the Zypad BR2000 provides for a variety of usage scenarios. This section describes the enclosure and mounting.

Enclosure

The Zypad BR2000 electronics are housed in a rugged, compact enclosure, that fits in the palm of your hand. This enclosure is designed for extreme temperatures, vibration, shock, and is sealed against exposure to the elements. External connections are made using MIL-performance, push-pull, single-grip, blind-mate connectors. For mechanical specifications, see [Mechanical](#), page 24. The enclosure is designed to be man-wearable or vehicle-mounted. It includes screw-down attachment points for direct fixed-mount or quick-release brackets allowing for a variety of mounting scenarios.

The following diagram illustrates a custom factory configuration for mounting hardware on the back of the enclosure.

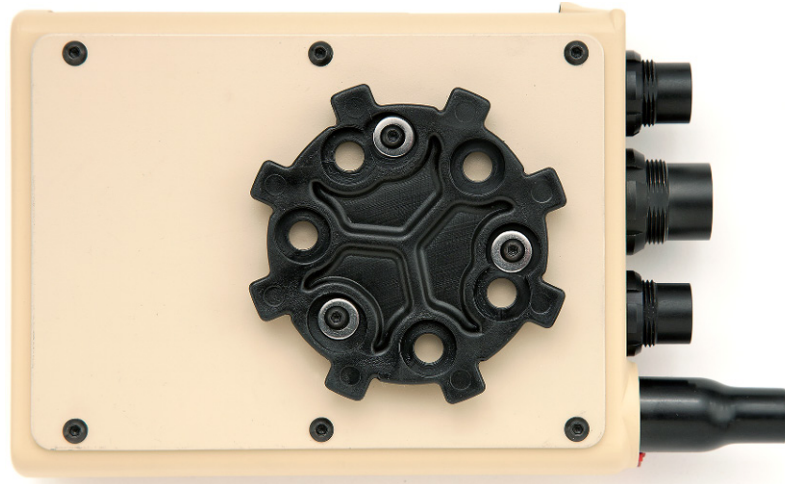

Figure 11. Enclosure, Rear View

Mounting Options

Wearable

As a wearable computer, the Zypad BR2000 is designed to be worn on a tactical vest, utility belt, pocket, or backpack. The following photograph shows the unit worn on a tactical vest.



Figure 12. Man-wearable Computer

Vehicle-mounted

Its small size, light weight, and low-power consumption make the Zypad BR2000 an ideal computing solution for Size, Weight, and Power (SWaP) constrained vehicle and aircraft platforms. It can easily be mounted inside small spaces.

System Specification

Processor

The Zypad BR2000 is based on the Intel® Atom™ processor E660T and is designed to meet the following performance specifications.

Parameter	Min	Typ.	Max	Units
Processor operating frequency (industrial temperature)			1.33	GHz

Power Supply

The Zypad BR2000 is designed to operate with the following power supply requirements.

Absolute Maximum Ratings

Supply Voltage (+V_DC_IN) 16 V max

Symbol	Parameter	Min	Typ.	Max	Units
Battery Pack (note 7)					
V _{OUT}	Supply voltage, battery power	3.0		3.7	V
	Run time (note 8)			6	Hours
DC Power Input (+V_DC_IN)					
V _{IN}	Supply voltage, regulated power	9		16	V
V _{TRANSIENT}	Input transient voltage			(TBD)	V
Auxiliary Power Output (J1_+5V, J2_+5V, J3_+5V)					
V _{OUT}	Output voltage		5		V
I _{OUT}	Output current per signal			1	A
Real-Time Clock Battery					
V _{OUT}	Supply voltage, BR1225 battery			3	V
	Shelf life, no power applied			50	Days
BTN_ONOFF#					
V _{IL}	Low-level input voltage			0.8	V
R _{PU}	Pull-up resistance		20		kΩ
V _{PU}			3.3		V

Note:

- 7. Compatible with deployed military batteries (i.e. LI-145, VA-5590).
- 8. Run time specified for a 30Wh battery pack capacity.

Display and Audio

The Zypad BR2000 is designed to meet the following display and audio specifications.

Symbol	Parameter	Min	Typ.	Max	Units
VGA Display Output					
R _{VGA}	Display cable impedance		75		Ω
DDC_CLK, DDC_DATA					
R _{PU}	Pull-up resistance		10		kΩ
V _{PU}			5		V
Microphone Input					
V _{IN}	Full scale input voltage	0.707	1.03		V _{rms}
Gain _{IN}	Microphone boost	0		30	dB
R _{IN}	Input impedance		50		kΩ
C _{IN}	Input capacitance		15		pF
Headphone					
P _{OUT}	Output power, 32Ω load	31	42		mW(peak)

Mechanical

The Zypad BR2000 is designed to meet the following mechanical requirements.

Parameter	Specification
Enclosure	Aluminium alloy, Corrosion resistant IEC 60529 IP67-Class (sealed against water, dust ingress) Desert Sand MIL-A-8625 Type II, Class II (other colors special order)
Dimensions (LxWxD)	138mm x 107mm x 36mm (5.45" x 4.20" x 1.40")
Weight	0.6 kg (1.4 lbs) total weight without battery 0.8 kg (1.8 lbs) total weight with battery

Environmental

The Zypad BR2000 is designed to meet MIL-STD-810G/SAEJ1455 (formal qualification testing is pending).

Parameter	Specification
Operating temperature: Man-wearable, battery power Vehicle-mounted, external power	-40°C to +55°C (local ambient) -40°C to +71°C (local ambient)
Storage temperature	-40°C to +85°C
Battery temperature rating	-40°C to +55°C
Operating shock	40g, 11ms, 3 pos/neg per axis, 18 terminal peak sawtooth pulses
Crash safety shock	75g, 11ms, 2 pos/neg per axis, total 12 sawtooth pulses
Random vibration	SAE J1455-2006, Vehicle Profile; MIL-STD-810G, Method 514
Relative humidity, non-condensing	Up to 95% @ 40°C (conformal coating optional)
Water immersion	1 meter submersion, 30 minutes (similar to IP67)
Dust ingress	Method 510.4, No dust ingress
Operational altitude	Sea level to ~20,000 ft (~6096 meters)

EMI/EMC

The Zypad BR2000 is designed to meet the following EMI/EMC requirements.

Requirement	Description
MIL-STD-461F	Conducted and Radiated Emissions/Susceptibility
IEC 61000-4-2	EMC – Part 4-2
EN 55022/CISPR22	Immunity and Emissions

Appendix A – Revision History

This manual applies to the current revision of the Zypad BR2000 as given in the following section.

Revision A

Initial release

Appendix B – Development System

The Zypad BR2000 Development System includes the following components:

- Zypad BR2000
- CompactFlash card loaded with Windows® Embedded Standard (installed in unit)
- CompactFlash card loaded with Wind River Linux
- Lithium-Ion battery pack
- Battery charger with AC power adapter
- Zypad BR2000 AC power adapter
- Starter cable set
- Utility USB flash drive
- Utiliboot USB flash drive (Wind River Linux OS recovery)
- Zypad BR2000 Documentation DVD including
 - Zypad BR2000 User Manual
 - Zypad BR2000 Development System Quick Start
 - WES OS Recovery Image

Ensure you have received all the components for your system. For details about getting started including starting the GPS and configuring the Wi-Fi, refer to the *Zypad BR2000 Quick Start (Eurotech document # 110125-2001)*.

Battery Charger

The Zypad BR2000 Development System includes battery charger with AC power adapter for charging up to four battery packs simultaneously. The following diagram shows this battery charger.



Figure 13. Battery Charger

Status Indicators

Each battery pack charging slot includes a LED indicating the charging status as described in the following table.

LED Color	Description
Blue	Indicates the battery is charging
Green	Indicates the battery is fully charged
Red	Indicates a fault has occurred

Table 9. Status LED

Starter Cable Set

The cable set included with the development system enables the developer to easily access the features that are provided on connectors J1, J2, and J3.

Cable 1: USB, Serial, Power Input, and Remote On/Off

Cable 1 mates with connector J1, page 19 providing three USB 2.0 host ports, two EIA-232 serial ports (3-wire), an input for an external DC power supply, and a remote power on/off control signal.

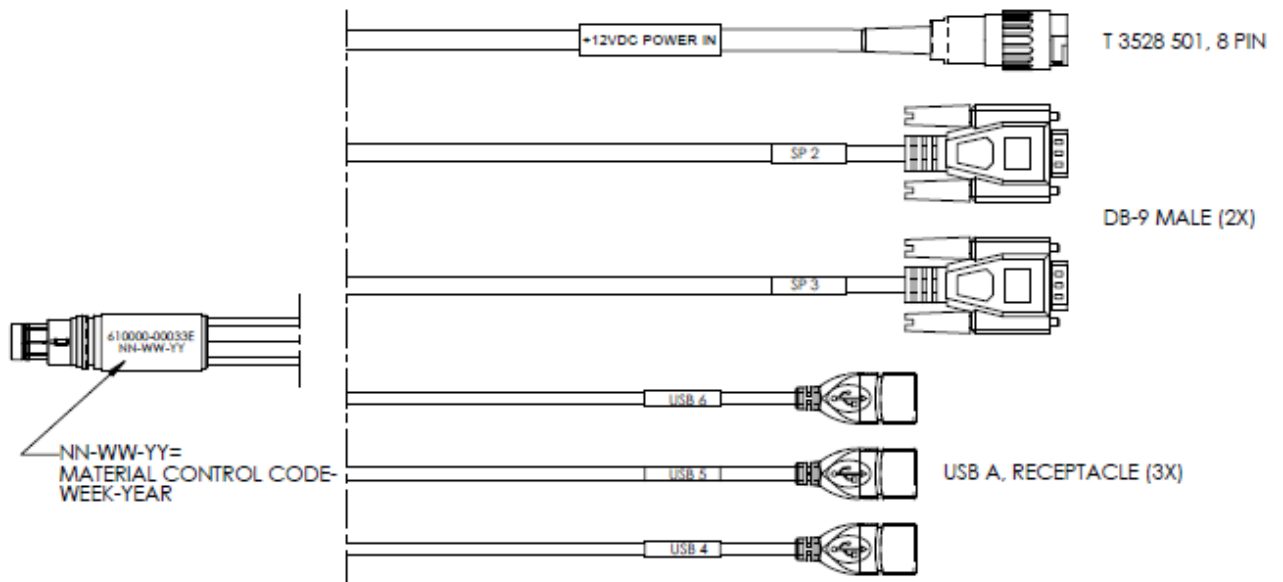
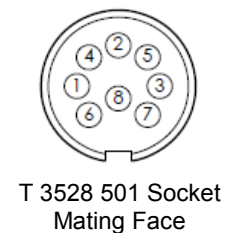

Figure 14. Cable 1

+12VDC Power In and Remote On/Off Control

The following table shows the pin assignment for the T 3528 501 8-pin socket. The connector body connects to the cable shield.

Pin	Name	Type	Description
1	NC		No connection
2	NC		No connection
3	NC		No connection
4	BTN_ONOFF#	I-3.3	Remote power on/off control
5	GND	P	Ground
6	+V_DC_IN	PI	+12V DC power input
7	NC		No connection
8	NC		No connection



SP 2 (EIA-232)

The following table shows the pin assignment for the SP 2 DB-9 plug. The shell connects to the cable shield.

Pin	Name	Type	Description
1	NC		No connection
2	RS232_B_TX	O	SP 2 (EIA-232), Transmit Data
3	RS232_B_RX	I	SP 2 (EIA-232), Receive Data
4	NC		No connection
5	GND	P	Ground
6	NC		No connection
7	NC		No connection
8	NC		No connection
9	NC		No connection

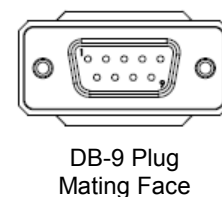

SP 3 (EIA-232)

The following table shows the pin assignment for the SP 3 DB-9 plug. The shell connects to the cable shield.

Pin	Name	Type	Description
1	NC		No connection
2	RS232_C_TX	O	SP 3 (EIA-232), Transmit Data
3	RS232_C_RX	I	SP 3 (EIA-232), Receive Data
4	NC		No connection
5	GND	P	Ground
6	NC		No connection
7	NC		No connection
8	NC		No connection
9	NC		No connection

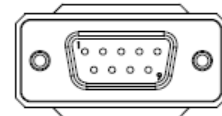

DB-9 Plug
Mating Face

USB 4

The following table shows the pin assignment for the USB 4 type A receptacle. The shell connects to the cable shield.

Pin	Name	Type	Description
1	J1_+5V	PO	+5V DC power output
2	USB_HOST4_N	IO-USB	USB 4
3	USB_HOST4_P		
4	GND	P	Ground

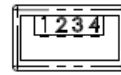

USB Socket
Mating Face

USB 5

The following table shows the pin assignment for the USB 5 type A receptacle. The shell connects to the cable shield.

Pin	Name	Type	Description
1	J1_+5V	PO	+5V DC power output
2	USB_HOST5_N	IO-USB	USB 5
3	USB_HOST5_P		
4	GND	P	Ground

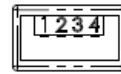

USB Socket
Mating Face

USB 6

The following table shows the pin assignment for the USB 6 type A receptacle. The shell connects to the cable shield.

Pin	Name	Type	Description
1	J1_+5V	PO	+5V DC power output
2	USB_HOST6_N	IO-USB	USB 6
3	USB_HOST6_P		
4	GND	P	Ground

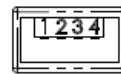

USB Socket
Mating Face

Cable 2: Audio, VGA Display, and USB

Cable 2 mates with connector J2, page 20 providing an audio input, audio output, VGA display output, and three USB 2.0 host ports.

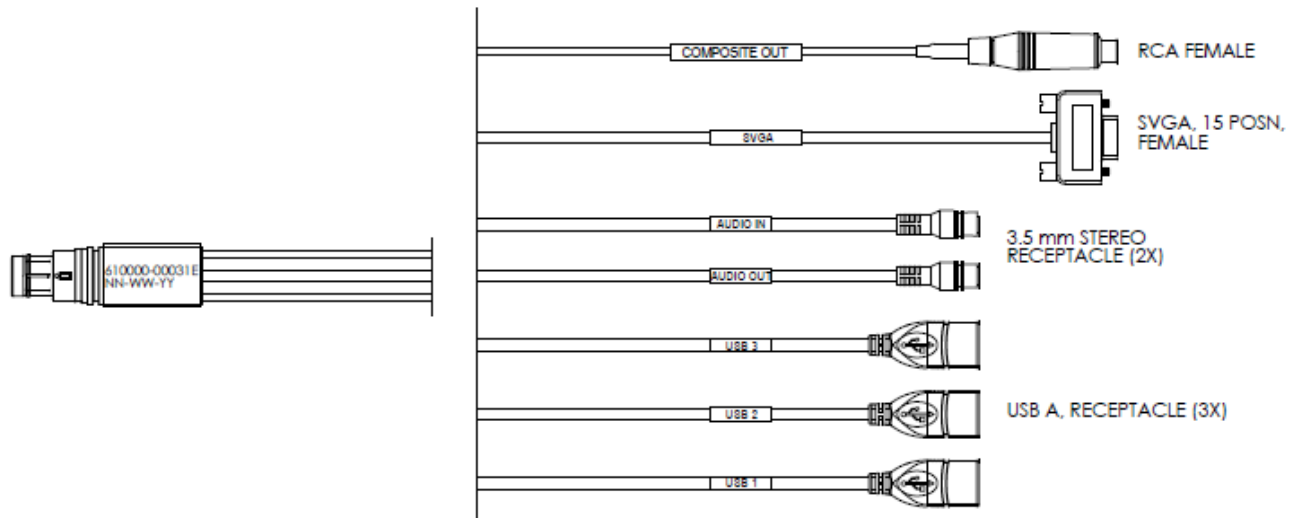

Figure 15. Cable 2

Composite Out (custom factory configuration)

The following table shows the pin assignment for the RCA socket. The composite video output is a custom factory configuration of the Zypad BR2000.

Pin	Name	Type	Description
Center	CBVS_VIDEO	AO	Composite video output
Shield	GND	P	Ground



RCA Socket Mating Face

SVGA

The following table shows the pin assignment for the SVGA 15-pin socket. The shell connects to the overall cable shield.

Pin	Name	Type	Description
1	RED_OUT	AO	Red data
2	GREEN_OUT	AO	Green data
3	BLUE_OUT	AO	Blue data
4	NC		No connection
5	GND	P	Ground
6	GND	P	Ground (Red data shield)
7	GND	P	Ground (Green data shield)
8	GND	P	Ground (Blue data shield)
9	NC		No connection
10	GND	P	Ground
11	NC		No connection
12	DDC_SDA	IO	DDC I ² C data
13	HSYNC_OUT	AO	Horizontal sync
14	VSYNC_OUT	AO	Vertical sync
15	DDC_SCL	O	DDC I ² C clock

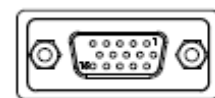

SVGA Socket Mating Face

Audio In

The following table shows the pin assignment for the 3.5mm stereo receptacle. The shield (sleeve) connects to ground.

Pin	Name	Type	Description
Tip	MIC_IN_L	AI	Microphone, Left channel
Ring	MIC_IN_R	AI	Microphone, Right channel



Stereo Receptacle
Mating Face

Audio Out

The following table shows the pin assignment for the 3.5mm stereo receptacle. The shield (sleeve) connects to ground.

Pin	Name	Type	Description
Tip	HP_OUT_L	AO	Headphone, Left channel
Ring	HP_OUT_R	AO	Headphone, Right channel



Stereo Receptacle
Mating Face

USB 1

The following table shows the pin assignment for the USB 1 type A receptacle. The shell connects to the shield.

Pin	Name	Type	Description
1	J2_+5V	PO	+5V DC power output
2	USB_HOST1_N	IO-USB	USB 1
3	USB_HOST1_P		
4	GND	P	Ground

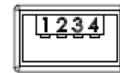

USB Socket
Mating Face

USB 2

The following table shows the pin assignment for the USB 2 type A receptacle. The shell connects to the shield.

Pin	Name	Type	Description
1	J2_+5V	PO	+5V DC power output
2	USB_HOST2_N	IO-USB	USB 2
3	USB_HOST2_P		
4	GND	P	Ground

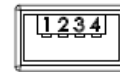

USB Socket
Mating Face

USB 3

The following table shows the pin assignment for the USB 3 type A receptacle. The shell connects to the shield.

Pin	Name	Type	Description
1	J2_+5V	PO	+5V DC power output
2	USB_HOST3_N	IO-USB	USB 3
3	USB_HOST3_P		
4	GND	P	Ground

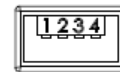

USB Socket
Mating Face

Cable 3: Ethernet, Serial, and Power Output

Cable 3 mates with connector J3 , page 21 providing an Ethernet interface, a full-function EIA-232 serial port (8-wire), and +5VDC power output.

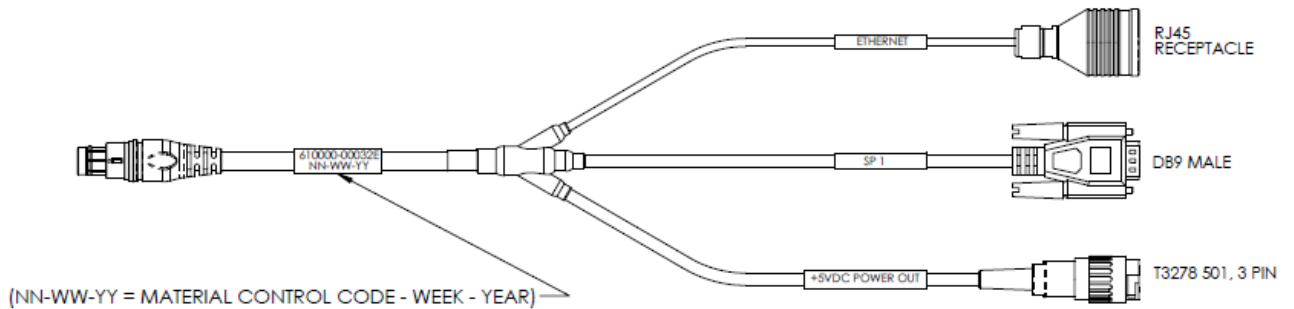
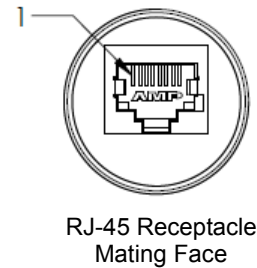

Figure 16. Cable 3

Ethernet

The following table shows the pin assignment for the Ethernet RJ-45 receptacle.

Pin	Name	Type	Description
1	MIDI0_T_P	IO-A	Channel 0, positive signal
2	MIDI0_T_N	IO-A	Channel 0, negative signal
3	MIDI1_T_P	IO-A	Channel 1, positive signal
4	MIDI2_T_P	IO-A	Channel 2, positive signal
5	MIDI2_T_N	IO-A	Channel 2, negative signal
6	MIDI1_T_N	IO-A	Channel 1, negative signal
7	MIDI3_T_P	IO-A	Channel 3, positive signal
8	MIDI3_T_N	IO-A	Channel 3, negative signal



SP 1 (EIA-232)

The following table shows the pin assignment for the SP 1 DB-9 plug. The shell connects to the cable shield.

Pin	Name	Type	Description
1	RS232_A_CD	I	Carrier Detect
2	RS232_A_RX	I	Receive Data
3	RS232_A_TX	O	Transmit Data
4	RS232_A_DTR	O	Data Terminal Ready
5	GND	P	Ground
6	RS232_A_DSR	I	Data Set Ready
7	RS232_A_RTS	O	Request To Send
8	RS232_A_CTS	I	Clear To Send
9	NC		No connection

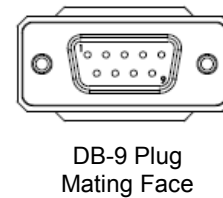

+5VDC Power Output

The following table shows the pin assignment for the T3578 501 3-pin socket. The body connects to the cable shield.

Pin	Name	Type	Description
1	J3_+5V	PO	+5V DC power output (software-controlled)
2	GND	P	Ground
3	GND	P	Ground

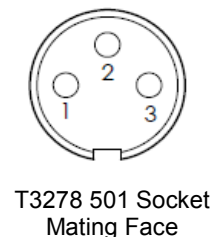

Eurotech Worldwide Presence

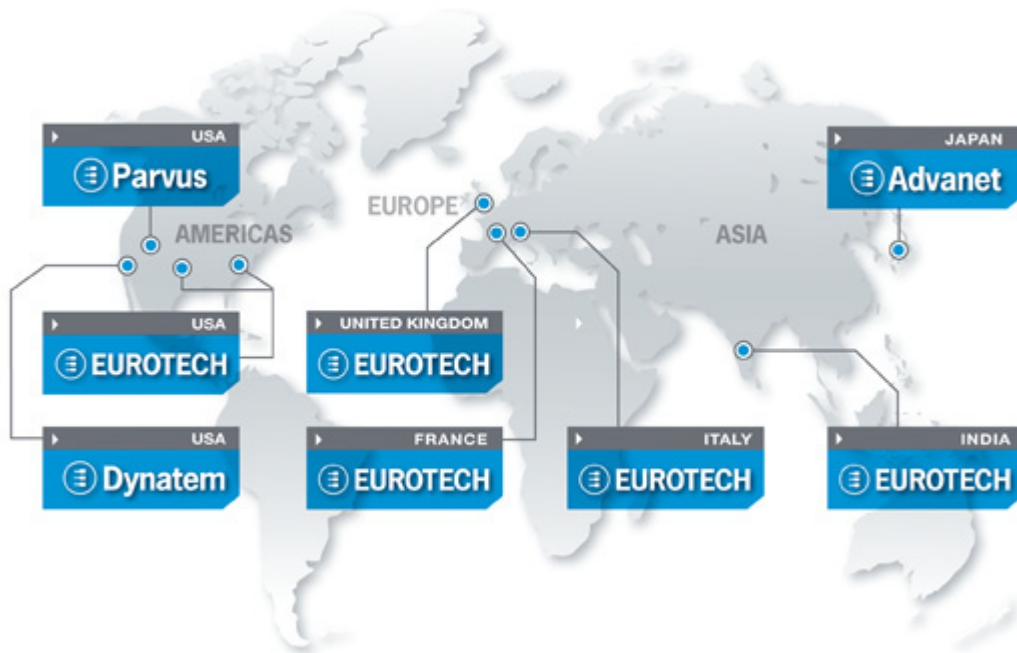

AMERICAS

USA



EUROTECH

Toll free +1 800.541.2003
 Tel. +1 301.490.4007
 Fax +1 301.490.4582
 E-mail: sales.us@eurotech.com
 E-mail: support.us@eurotech.com
 Web: www.eurotech-inc.com

PARVUS

Tel. +1 800.483.3152
 Fax +1 801.483.1523
 E-mail: sales@parvus.com
 E-mail: tsupport@parvus.com
 Web: www.parvus.com

DYNATEM

Tel. +1 800.543.3830
 Fax +1 949.770.3481
 E-mail: sales@dynatem.com
 E-mail: tech@dynatem.com
 Web: www.dynatem.com

EUROPE

Italy

EUROTECH

Tel. +39 0433.485.411
 Fax +39 0433.485.499
 E-mail: sales.it@eurotech.com
 E-mail: support.it@eurotech.com
 Web: www.eurotech.com

United Kingdom

EUROTECH

Tel. +44 (0) 1223.403410
 Fax +44 (0) 1223.410457
 E-mail: sales.uk@eurotech.com
 E-mail: support.uk@eurotech.com
 Web: www.eurotech-ltd.com

France

EUROTECH

Tel. +33 04.72.89.00.90
 Fax +33 04.78.70.08.24
 E-mail: sales.fr@eurotech.com
 E-mail: support.fr@eurotech.com
 Web: www.eurotech.com

ASIA

Japan

ADVANET

Tel. +81 86.245.2861
 Fax +81 86.245.2860
 E-mail: sales@advanet.co.jp
 E-mail: tsupport@advanet.co.jp
 Web: www.advanet.co.jp

India

EUROTECH

Tel. +91 80.43.35.71.17
 E-mail: sales.in@eurotech.com
 E-mail: support.in@eurotech.com
 Web: www.eurotech.com



www.eurotech.com

EUROTECH HEADQUARTERS

Via Fratelli Solari 3/a

33020 Amaro (Udine) – ITALY

Phone: +39 0433.485.411

Fax: +39 0433.485.499

For full contact details go to: www.eurotech.com/contacts