

REVISIONS			
LTR	DESCRIPTION	DATE	APPVL
B	Production Release	04/15/08	

These materials are being provided for the purpose of acquainting certain parties with Applied Data Systems, Inc. ("ADS") and its technology and evaluating whether to pursue a possible transaction with ADS. These materials contain proprietary information ("Confidential Information") relating to the technology, business affairs and/or operations of ADS, which is not publicly available. By reviewing or taking receipt of these materials, the Recipient acknowledges and agrees that the Confidential Information in the materials is confidential and proprietary in nature, that Recipient will not use such Confidential Information for any purpose other than the evaluation of a possible transaction with ADS, including, any competitive purpose, and that Recipient will not disclose any or all of the Confidential Information in any form to any other party. If Recipient does not agree to these conditions, Recipient will immediately notify ADS in writing and return the materials to ADS. Recipient will not duplicate the Confidential Information and will return all materials to ADS upon its request.

APPROVALS				Applied Data Systems, Inc. 10260 Old Columbia Road, Columbia, Maryland 21046		
ORIGINATOR:	DATE	ENGINEER DIRECTOR:	DATE	TITLE		
				<b>SCHEMATIC, CATALYST CARRIER BOARD</b>		
CHECKED:	DATE	CONFIGURATION MGR:	DATE	SIZE	DRAWING NUMBER	REV
				<b>B</b>	<b>640122-300R</b>	<b>B</b>
				SCALE 1/1	© Copyright 2006 Applied Data Systems, Inc. All Rights Reserved	COVER SHEET

# Catalyst Carrier Board Schematic

<Variant Name>

		-	-
		-	-
		-	-
-	-	-	-
-	-	-	-
B	See udpates 3-25-08 thru 4-9-08	04/09/08	CA
A	See udpates 2-26-08	02/26/08	CA
Rev	Description / ECN	Date	Ini.
Title		APPLIED DATA SYSTEMS, INC. 10260 Old Columbia Rd, Suite G Columbia, MD 21046 1-800-541-2003	
Size	Document Number	Rev	
	640122-300R	B	
Date:	Monday, April 14, 2008	Sheet	1 of 33

# Revision History

## 11-7-07-A Changes

p15 Added SIM Connector (Symbol must be replaced with ADS symbol)  
 p30 & 31 Changed R394 & R402 to 1% to reduce part count.  
 p24 Swapped voltage dividers resistor placement and changed R337 to 3.4K to reduce part count  
 p16 Changed package on C167, C169, C179 & C183 to reduce part count.  
 p7 Replaced R32 with 221 ohm resistor to reduce part count.  
 p6, 8, 11 & 19 Changed C00021-00073E to C00021-00080E to reduce part count.  
 p16 Changed package size on C170 & C171 to reduce package count.  
 p19, 20 & 21 Replaced all 2N2002 parts with updated symbol.  
 p4 Added Test points to SMB\_ALERT and USB\_OC3 & 5

### 11-8-08 Changes

p24 Replaced OS1 with SMT part.  
 p24 Replaced R309-R313, R323-R332 & R339-R351 with 1K R-pack.  
 p24 Replaced R352-R385 with 10K R-pack and R359-R368 with 100K R-pack.  
 p20 Added part of Over/Under voltage protection for +VBRICK and replaced J29.  
 p6 Replaced MMC connectors.  
 p16 Added Audio Ports E & F back into schematic.  
 p22 Added Front Panel Header.  
 p17 Added C364 & R418 to U14.

### Changes from 11-9-07 to 11-9-07-a

p9 & 11 Changed DEVICE and IPN property from C35285-004 to C35285-016 for Both J10 & J12.  
 11-14-07 Changes

Replaced 210070-00321E, 210070-00322E & 210070-00324E symbols.  
 Added netnames to SLOT0\_CD#\_R, SLOT0\_WP\_R and UART2\_SHUTDOWN nets.  
 Changed net name USBPWR\_CLLIENT to USBPWR\_CLIENT

p15 Added Mini-Addin Card Radio Disable switch and LED's.  
 p16 Added R427 and R428 series resistors to Audio Port E  
 p19 Replaced B1 Battery Socket.

### 11-26-07 Changes

p7 Deleted J9 (IDE Ziff Connector) and R33 (Series resistor for IDE Ziff Connector IDE\_RST#).  
 p12 Deleted C66, C67, R82, R83, R86 & R87 (unneeded Caps and resistors on PCIe CLK input to clock buffer).  
 p16 Deleted J20, J21 & J24 and replaced with stacked connector J20.  
 p16 Changed note R139 and R144 to place close to U12 instead of U1.  
 p17 Changed C364 to .22uF and added R448.  
 p18 Replaced U16 with different package part.

### 11-27-07

p15 Replaced U50 symbol.

### 12-10-07 Changes

See change log: 640122-300R0-00\_12-10-07\_JW.doc

### Changes 2-26-08 from Rev 1 to Rev. A

P. 16 Updated symbol for J20 to add shell connections to CGND  
 P. 20 Swap +VBRICK\_IN and GND on J29, input power connector  
 P. 20 Added RC to the enable of U37 to prevent droop on +VBRICK\_IN when enabled (R548, C517, C518)  
 P. 20 Added cap (C519 DNI) to OV\_SET to keep droop from appearing as UV event to LTC2912  
 P. 21 changed pull up of Q41 - Q43 to prevent from turning on when no ATX supply, also added RC to gates  
 P. 24 connected PE to pull up; named net SIO\_DSKCHG  
 P. 24 connected SIO\_PWR to unnamed net powering SIO  
 P. 28 named net DCD3\_I

### Changes 3-25-08 Rev A to Rev B

p.22 add pull down to JTAG\_TRST#  
 p.21 add 3x .1uf caps to slow turn on of +V\*S and +V\* rails  
 p.16 swap right and left on stacked audio connector  
 p.19 change C249 to 0402 footprint to match BOM  
 p.21 add option PU of ATX\_EN# and ATX\_ENG to +V\_ON  
 p,15 add PU to gate of FETS on LEDs to disable when no card installed  
 p.21 DNI R275 - PU on Core  
 p.21 move gate of Q45 to ATX\_EN  
 p.24 change PU to PD on CTS5\_SIO for revision indication  
 p.33 add power monitor circuit, added page  
 p.18 add strapping options on CPLD for revision indication  
 p.18 add UART\_TX to CPLD to read power measurement  
 p.22 add I2C GPIOs

### Changes 4-4-08

P. 22 Replace Thermal sensor with LM75  
 P. 26 Added jumper to enable /disable EIA-232 ports  
 P. 18 Added pull up to Carrier\_Therm\_Alert2#- no longer supported

### Changes 4-09-08

p.19 add cap to delay start of 1.8V LDO

### <Variant Name>

Rev	Description / ECN	Date	Ini.
		-	-
		-	-
		-	-
		-	-
		-	-
B	See updates 3-25-08 thru 4-9-08	04/09/08	CA
A	See updates 2-26-08	02/26/08	CA

Title		APPLIED DATA SYSTEMS, INC. 10260 Old Columbia Rd, Suite G Columbia, MD 21046 1-800-541-2003	
Size	Document Number	Rev	
	640122-300R	B	
Date:	Monday, April 14, 2008	Sheet	2 of 33

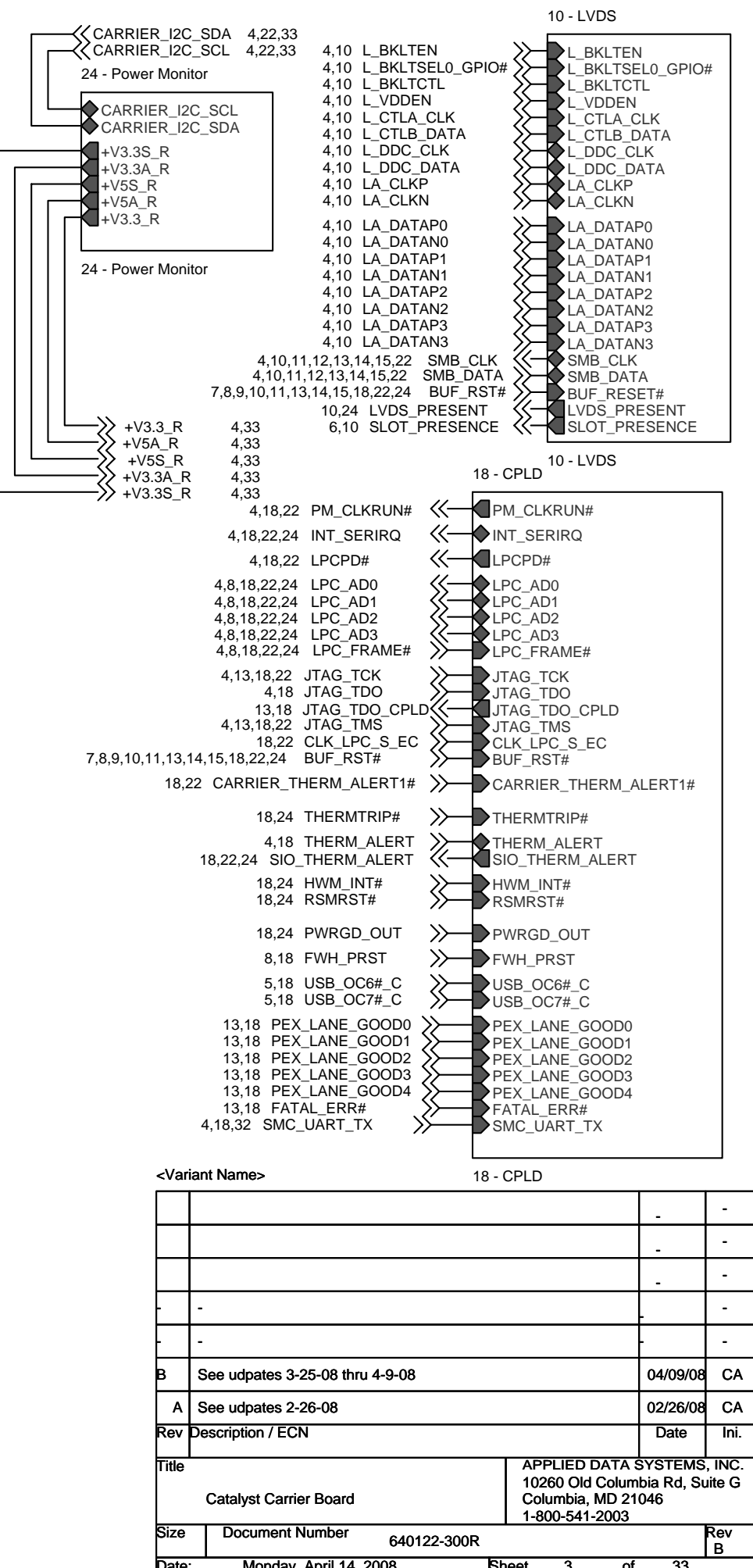
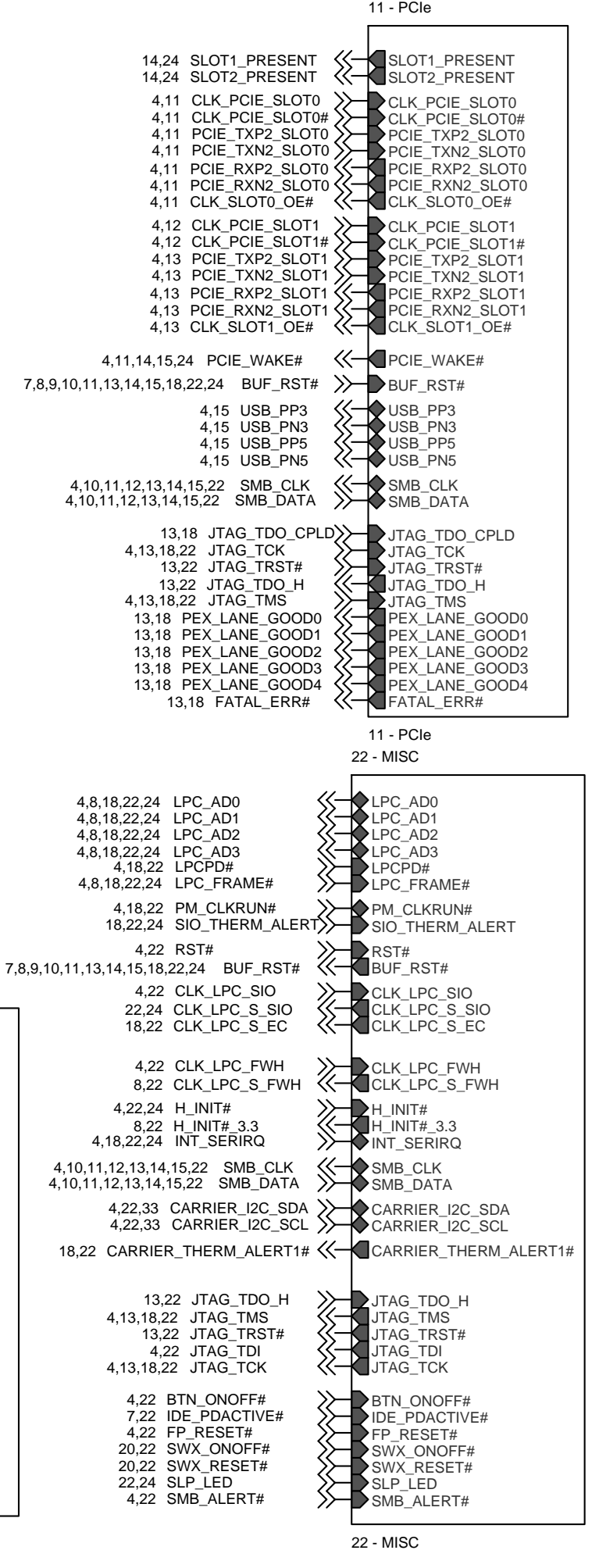
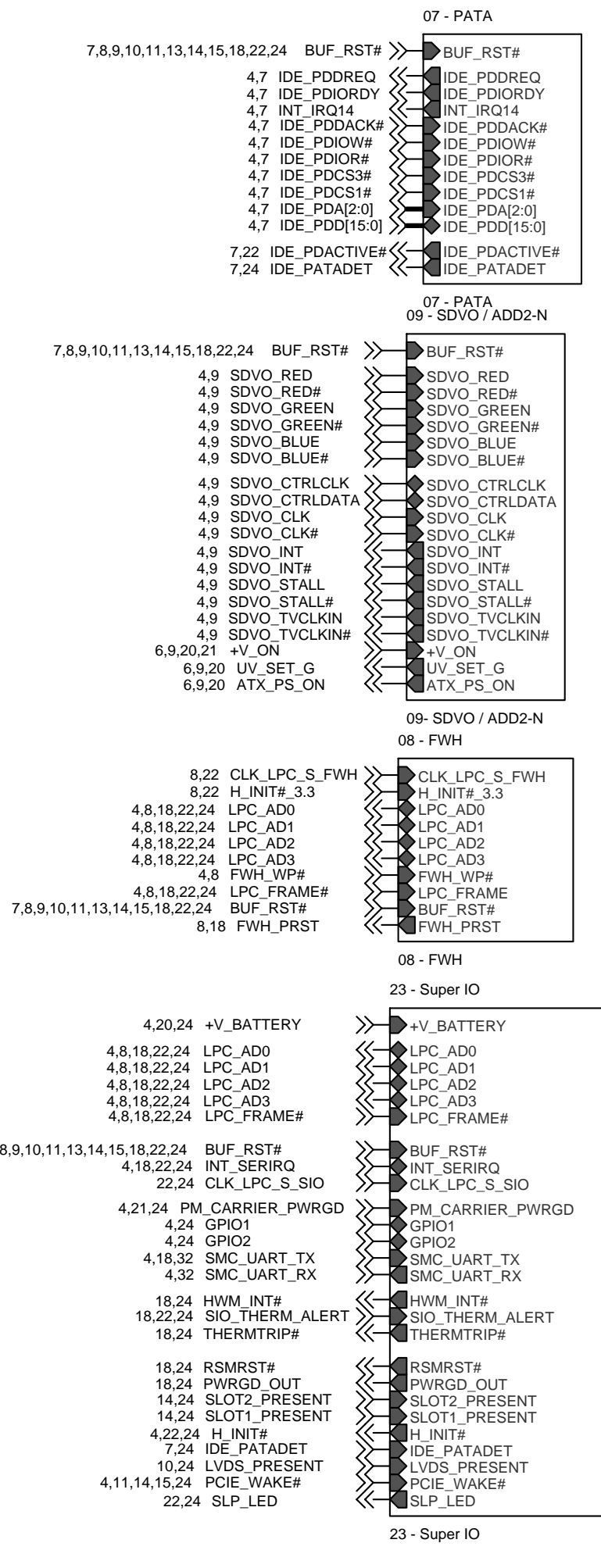
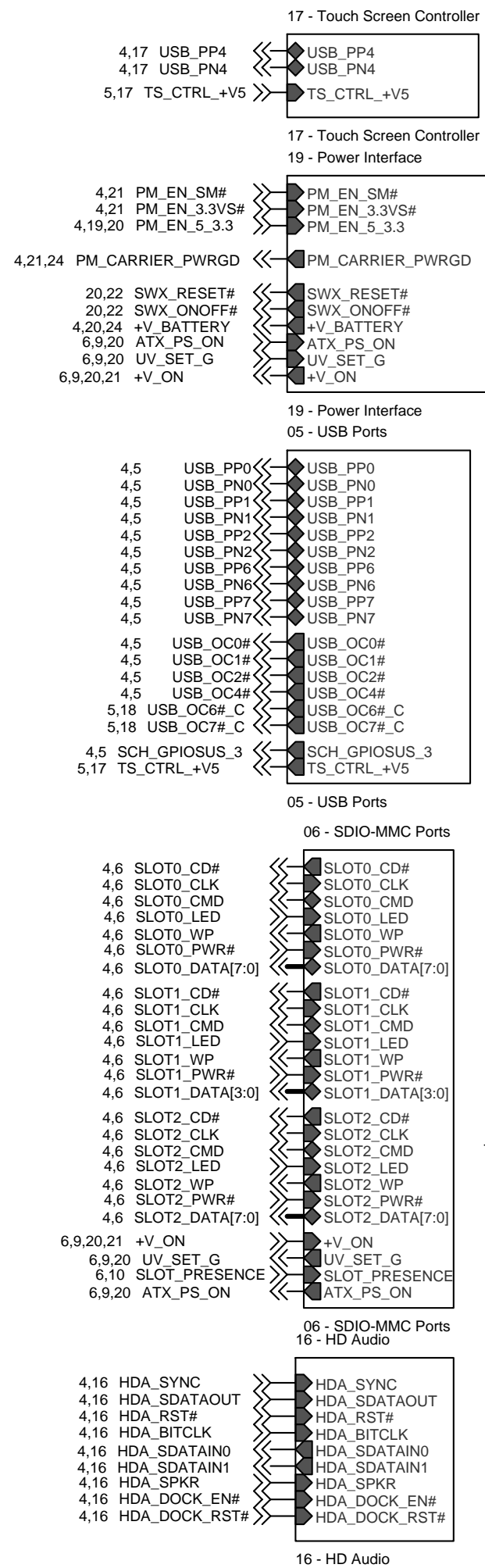

Rev	Description / ECN	Date	Ini.
B	See updates 3-25-08 thru 4-9-08	04/09/08	CA
A	See updates 2-26-08	02/26/08	CA

  

Title		APPLIED DATA SYSTEMS, INC.	
Catalyst Carrier Board		10260 Old Columbia Rd, Suite G Columbia, MD 21046 1-800-541-2003	
Size	Document Number	640122-300R	Rev B
Date:	Monday, April 14, 2008	Sheet	3 of 33

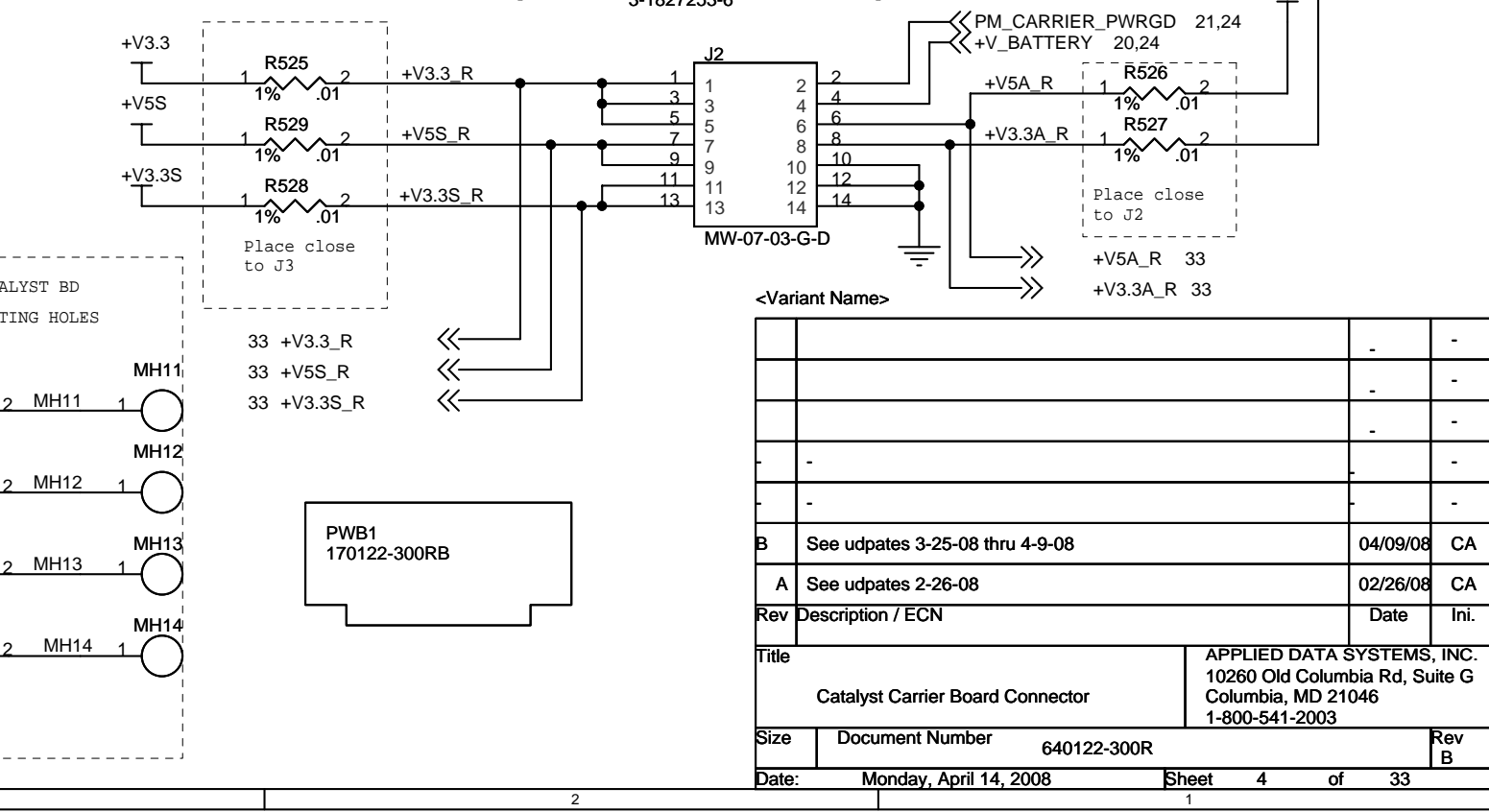
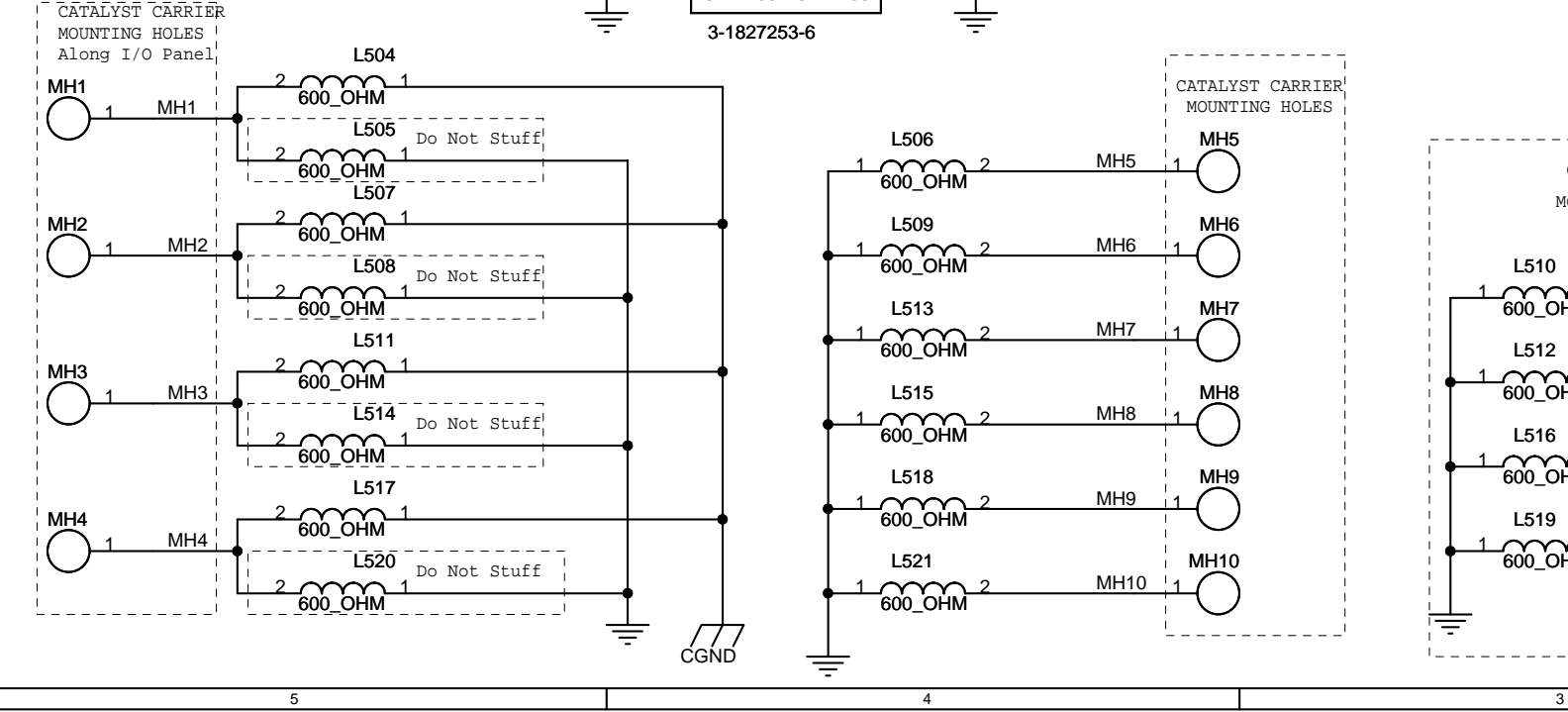
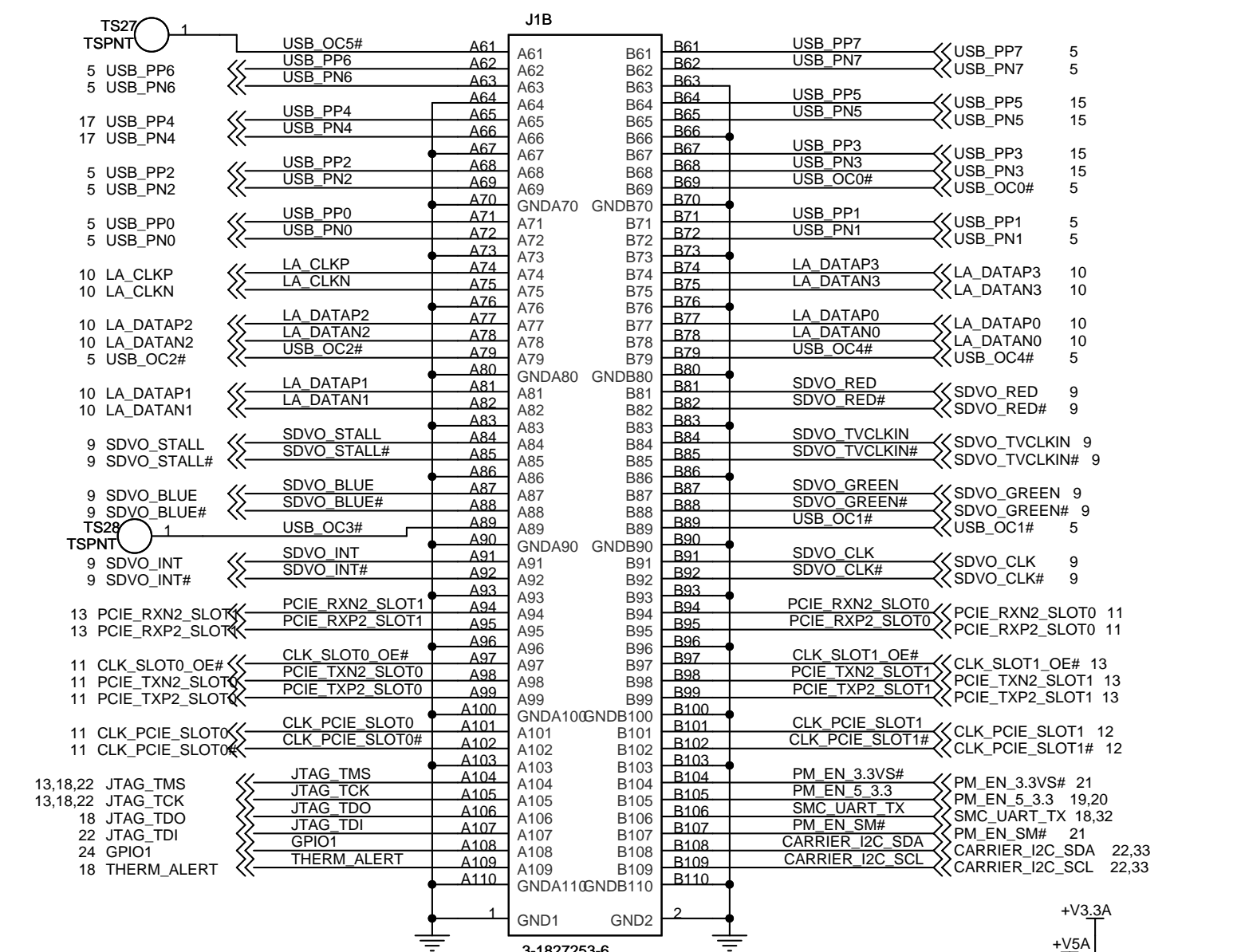
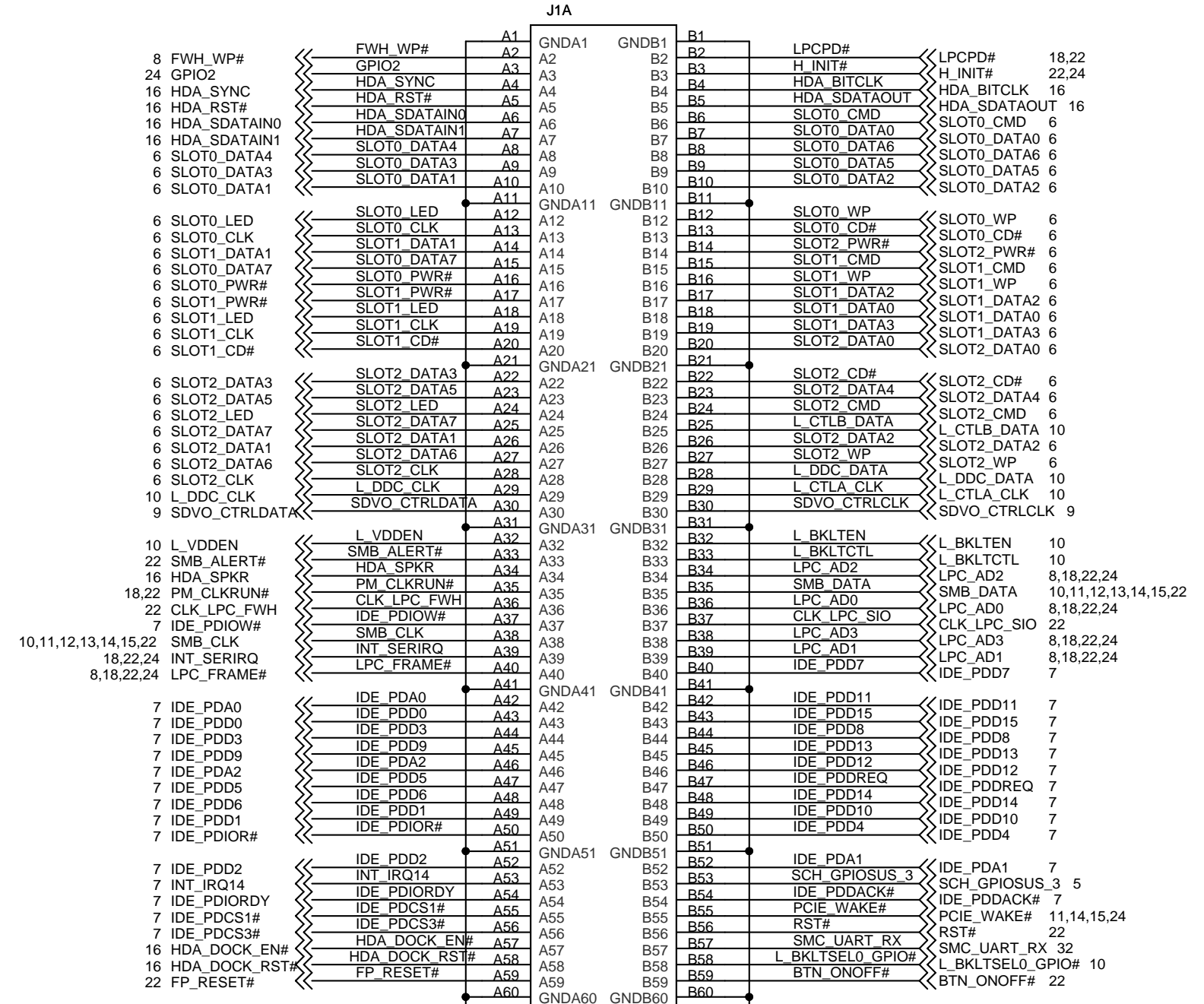

Rev	Description / ECN	Date	Ini.
B	See updates 3-25-08 thru 4-9-08	04/09/08	CA
A	See updates 2-26-08	02/26/08	CA

Title		APPLIED DATA SYSTEMS, INC.	
Catalyst Carrier Board Connector		10260 Old Columbia Rd, Suite G Columbia, MD 21046 1-800-541-2003	
Size	Document Number	Rev	
	640122-300R	B	
Date:	Monday, April 14, 2008	Sheet	4 of 33

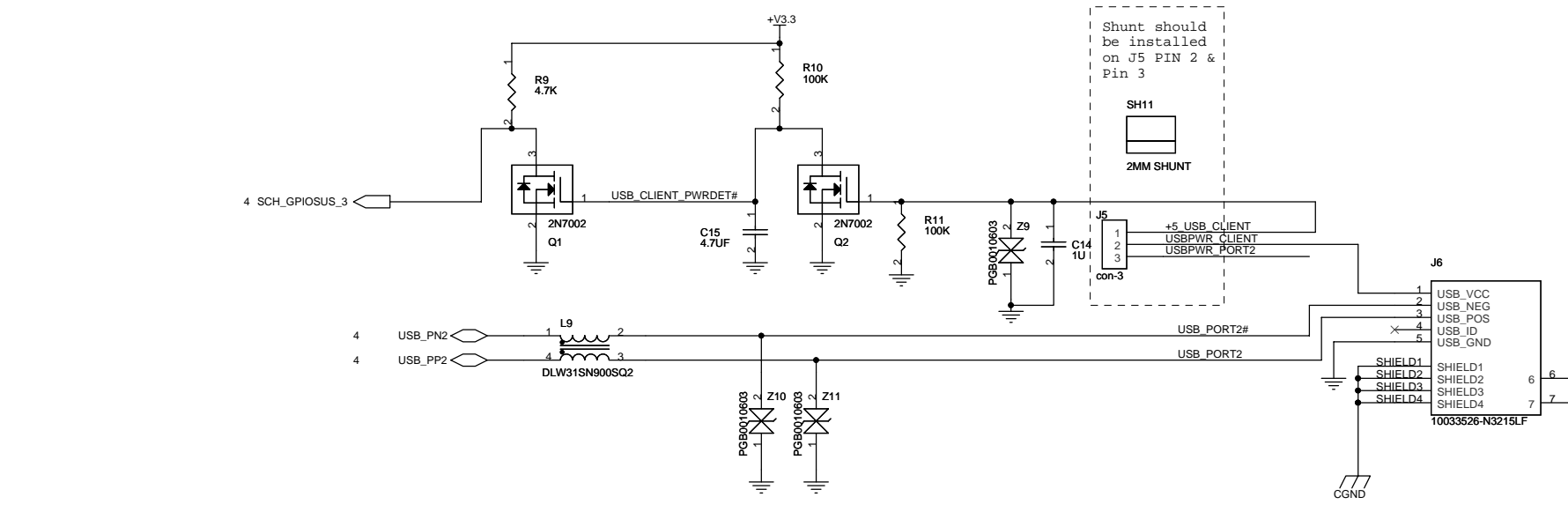
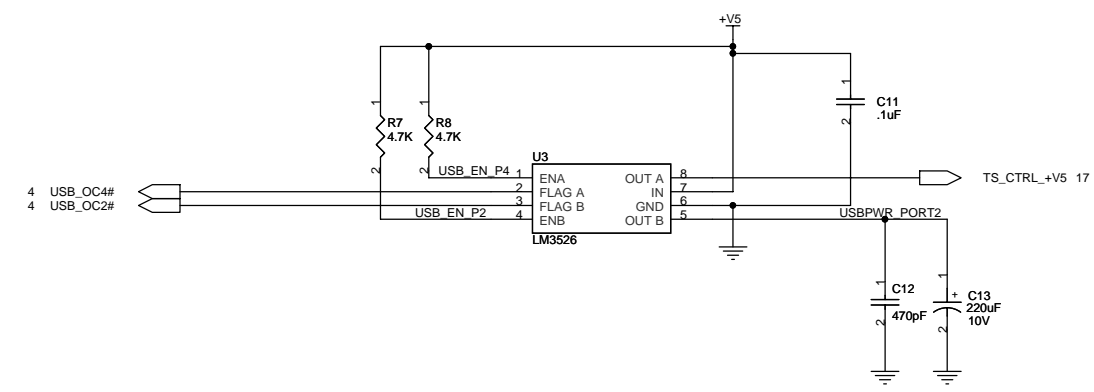
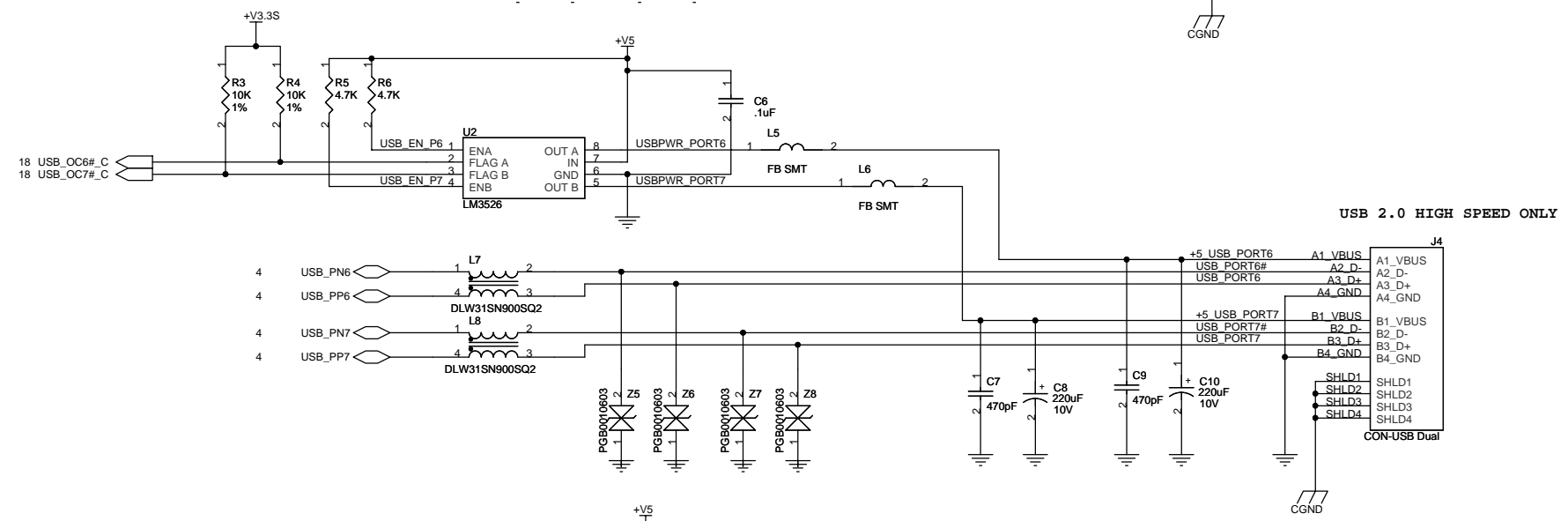
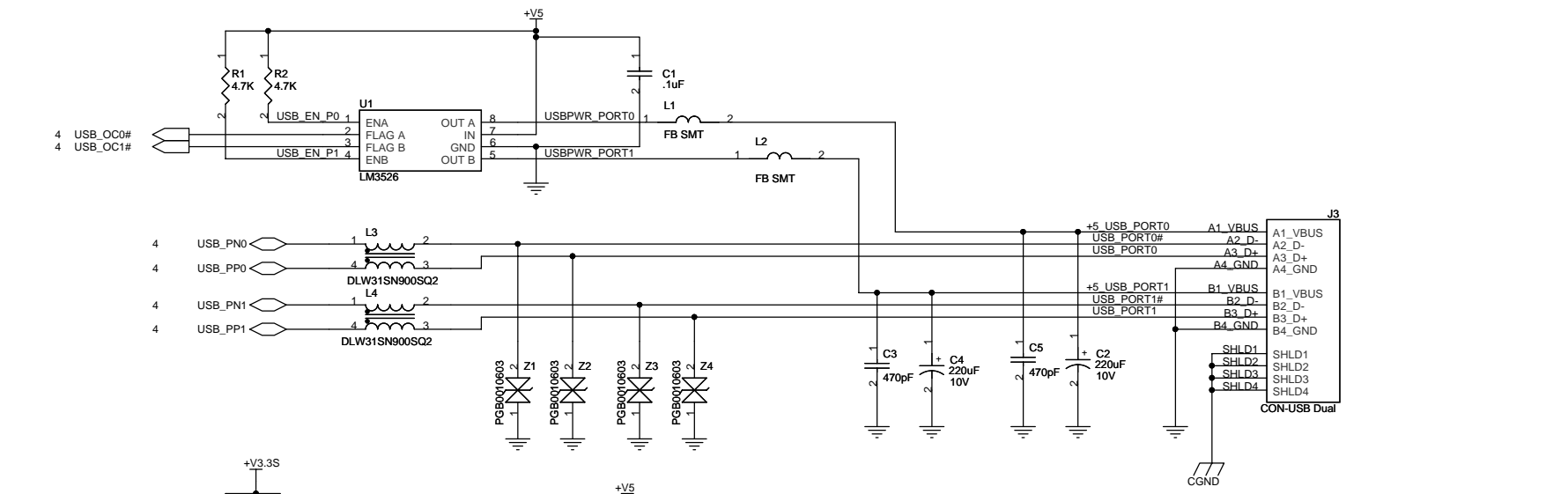

<Variant Name>

B	See updates 3-25-08 thru 4-9-08	04/09/08	-
A	See updates 2-26-08	02/26/08	CA
Rev	Description / ECN	Date	Ini.
Title		APPLIED DATA SYSTEMS, INC. 10260 Old Columbia Rd, Suite G Columbia, MD 21046 1-800-541-2003	
Size	Document Number	640122-300R	Rev
Date:	Monday, April 14, 2008	Sheet	5 of 33



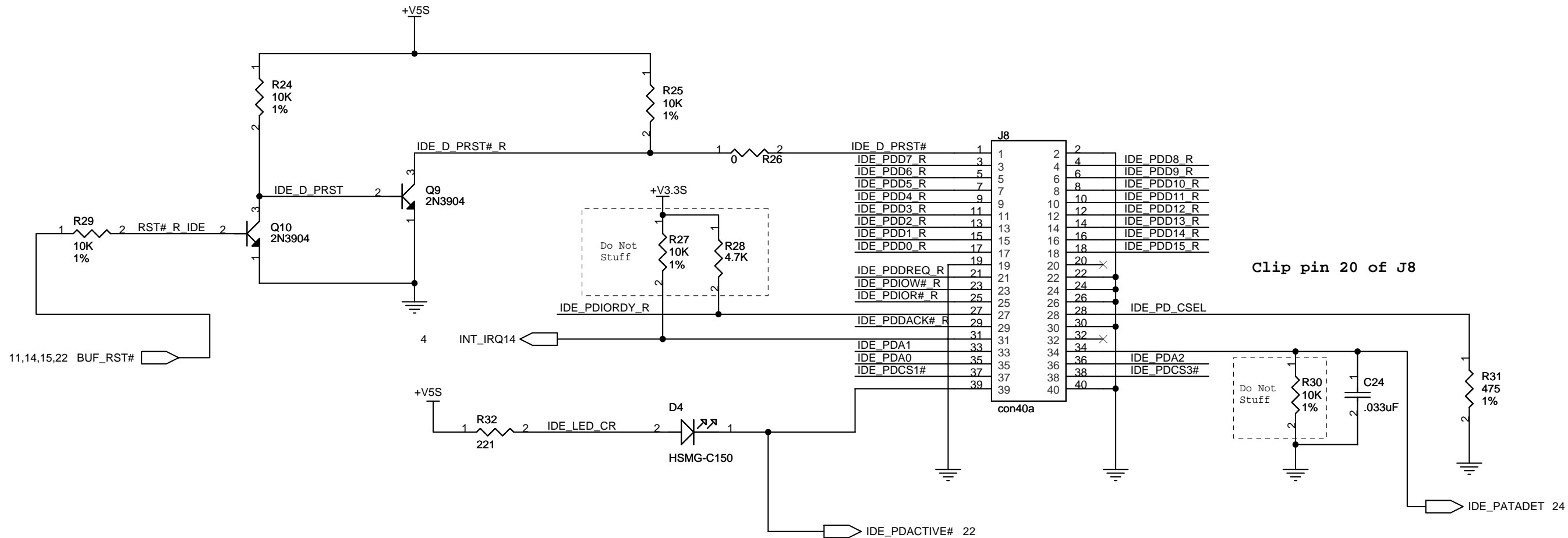

Place as close to IDE connectors as possible.

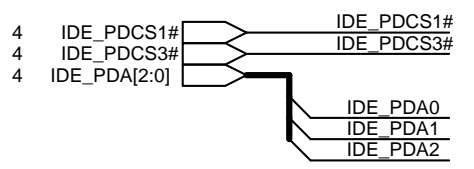
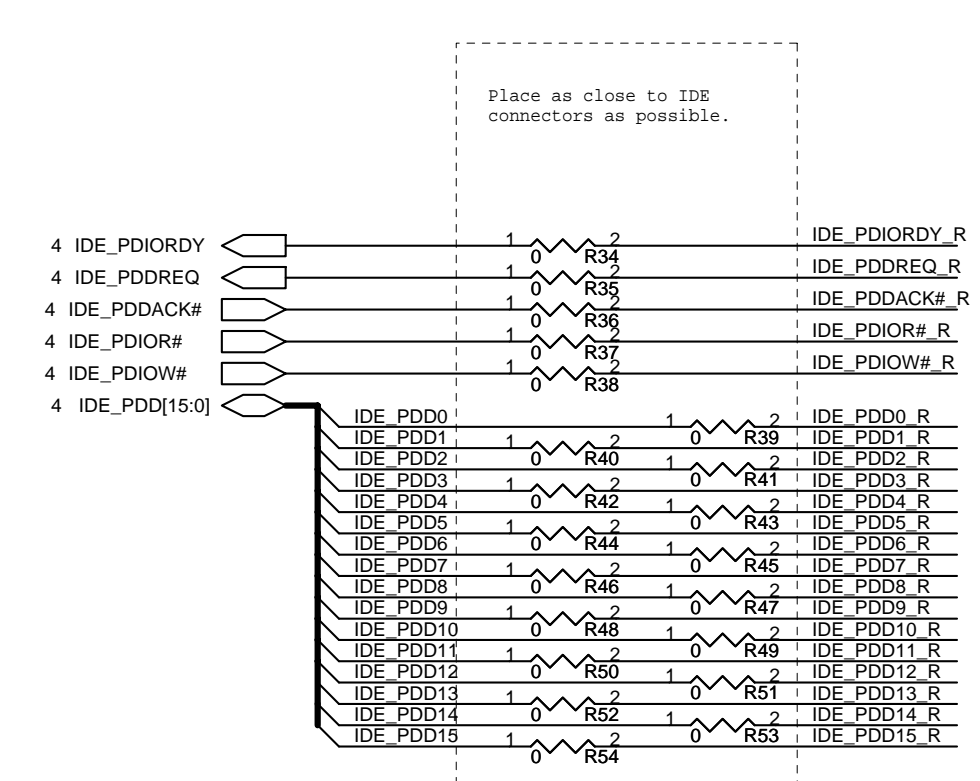

<Variant Name>			
Rev	Description / ECN	Date	Ini.
B	See updates 3-25-08 thru 4-9-08	04/09/08	CA
A	See updates 2-26-08	02/26/08	CA
Title		APPLIED DATA SYSTEMS, INC. 10260 Old Columbia Rd, Suite G Columbia, MD 21046 1-800-541-2003	
Size	Document Number	640122-300R	Rev B
Date:	Monday, April 14, 2008	Sheet	7 of 33



HW1	210041-03210E	PLCC SOCKET, 32 PIN, SMT	U6
-----	---------------	--------------------------	----

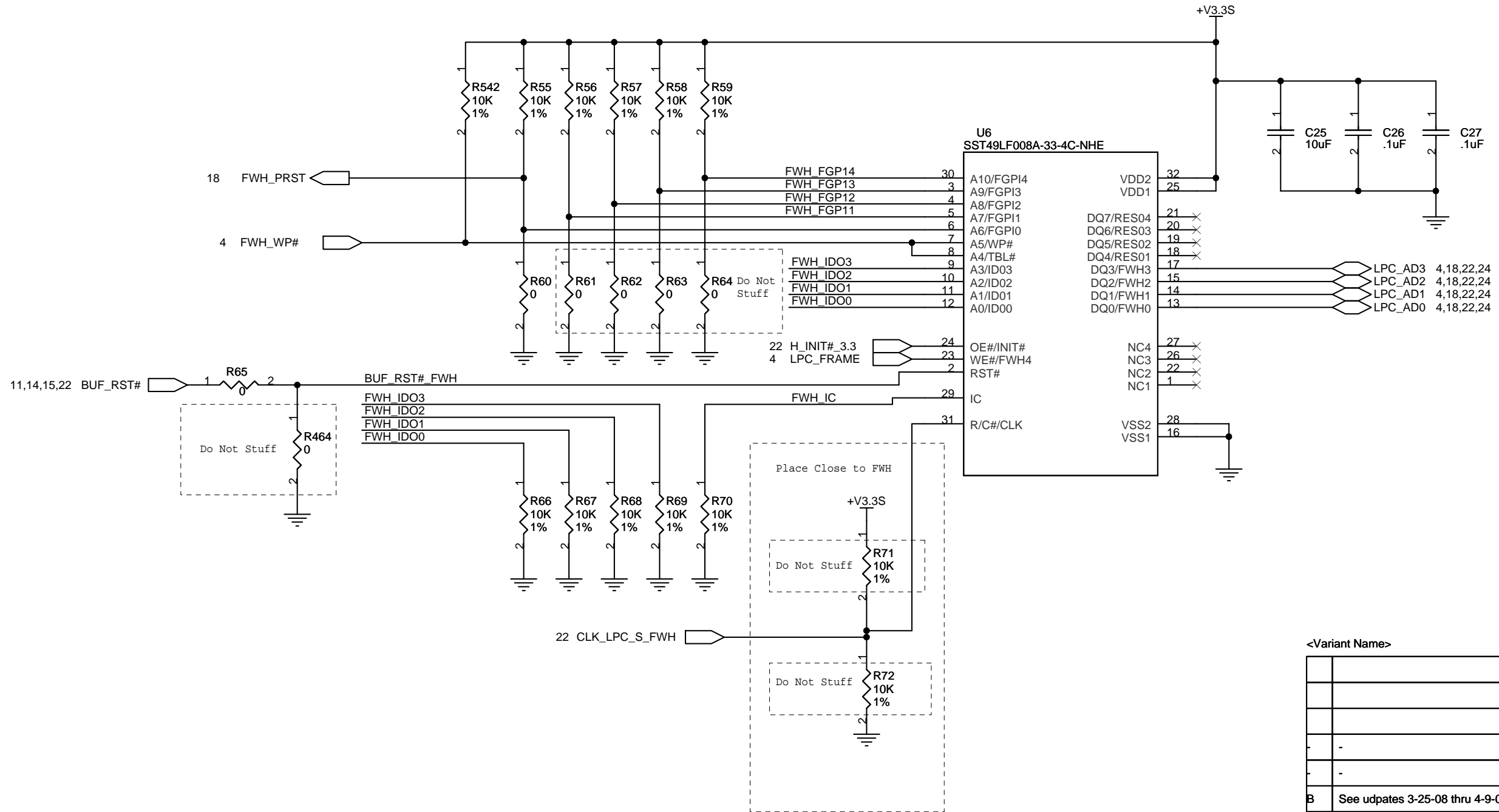

<Variant Name>			
Rev	Description / ECN	Date	Ini.
B	See updates 3-25-08 thru 4-9-08	04/09/08	CA
A	See updates 2-26-08	02/26/08	CA
Title		APPLIED DATA SYSTEMS, INC. 10260 Old Columbia Rd, Suite G Columbia, MD 21046 1-800-541-2003	
Size	Document Number	Rev	
	640122-300R	B	
Date:	Monday, April 14, 2008	Sheet	8 of 33

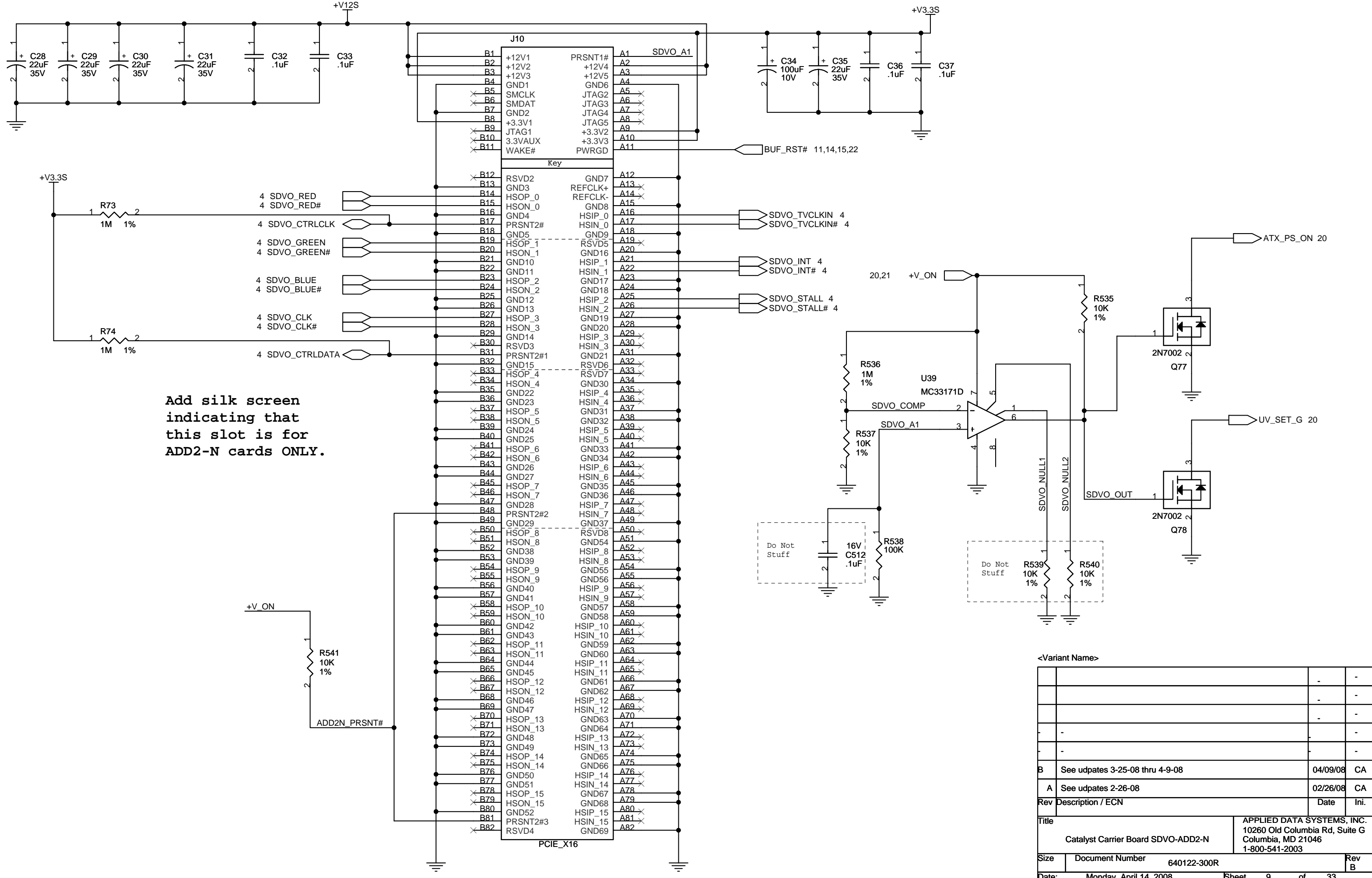

Add silk screen indicating that this slot is for ADD2-N cards ONLY.

<Variant Name>			
B	See updates 3-25-08 thru 4-9-08	04/09/08 CA	
A	See updates 2-26-08	02/26/08 CA	
Rev	Description / ECN	Date	Ini.
Title		APPLIED DATA SYSTEMS, INC. 10260 Old Columbia Rd, Suite G Columbia, MD 21046 1-800-541-2003	
Size	Document Number	640122-300R	Rev B
Date:	Monday, April 14, 2008	Sheet 9 of 33	

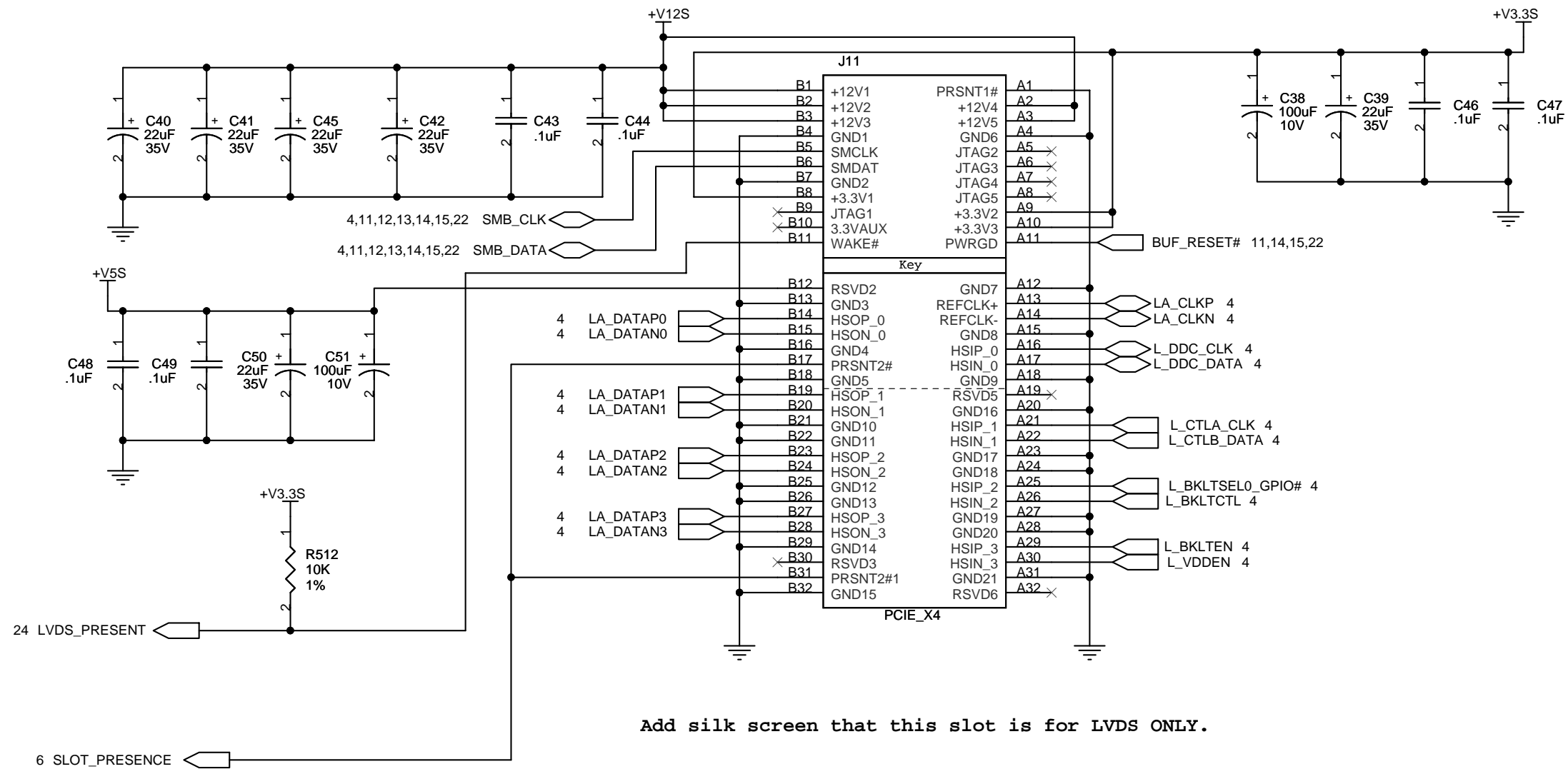

Add silk screen that this slot is for LVDS ONLY.

<Variant Name>

Rev	Description / ECN	Date	Ini.
B	See updates 3-25-08 thru 4-9-08	04/09/08	CA
A	See updates 2-26-08	02/26/08	CA
Title: Catalyst Carrier Board LVDS			
APPLIED DATA SYSTEMS, INC. 10260 Old Columbia Rd, Suite G Columbia, MD 21046 1-800-541-2003			
Size	Document Number	640122-300R	Rev B
Date:	Monday, April 14, 2008	Sheet 10 of 33	

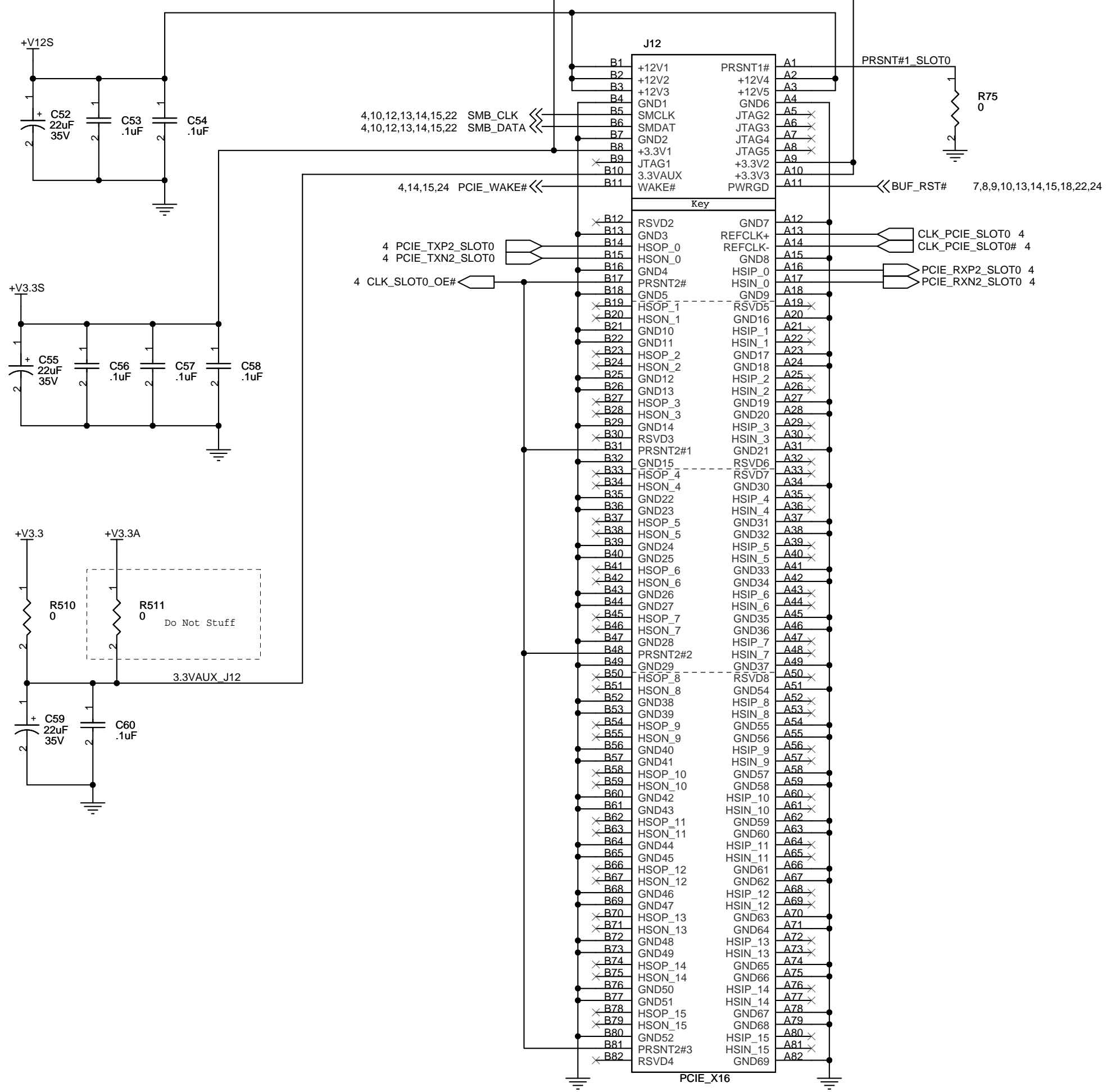

<Variant Name>

		-	-
		-	-
		-	-
		-	-
		-	-
B	See updates 3-25-08 thru 4-9-08	04/09/08	CA
A	See updates 2-26-08	02/26/08	CA
Rev	Description / ECN	Date	Ini.
Title		APPLIED DATA SYSTEMS, INC. 10260 Old Columbia Rd, Suite G Columbia, MD 21046 1-800-541-2003	
Size	Document Number	640122-300R	Rev B
Date:	Monday, April 14, 2008	Sheet	11 of 33

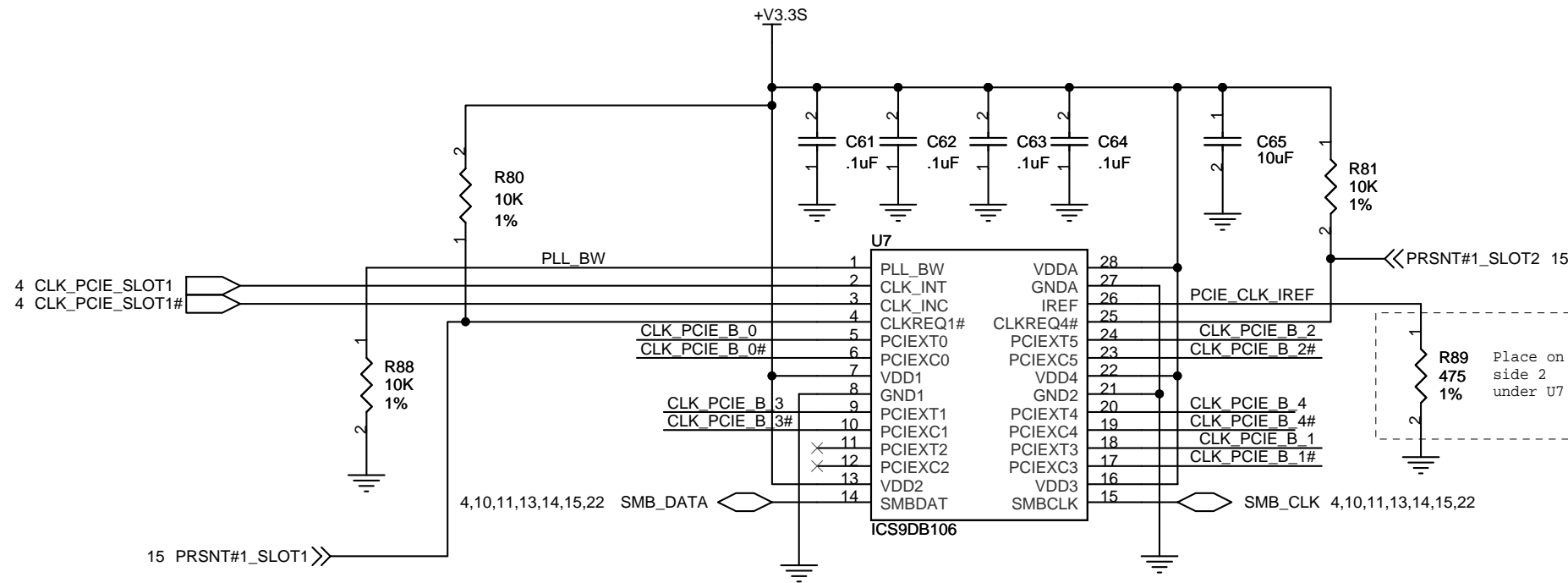

SM BUS ADDR  
1101010 = D4 for writes, D5 for reads

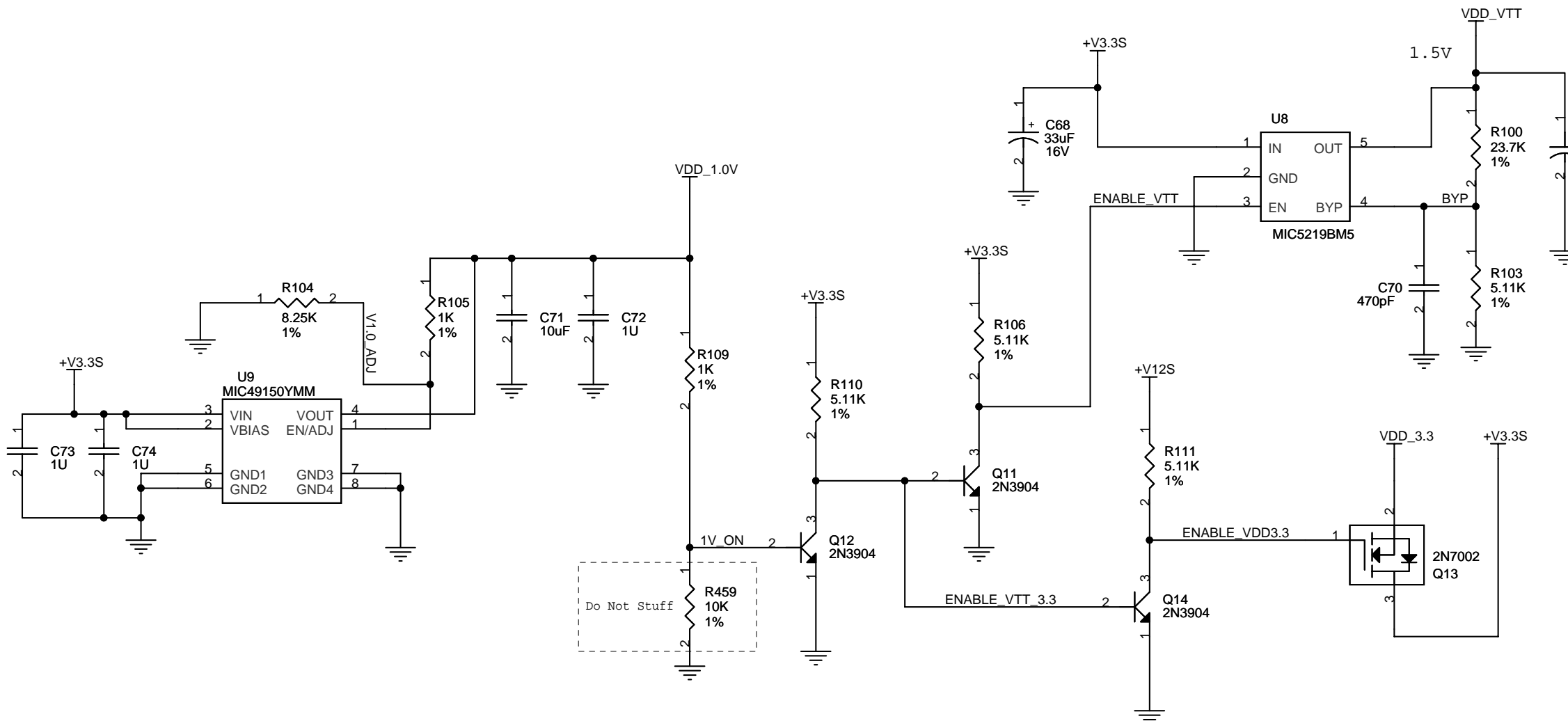
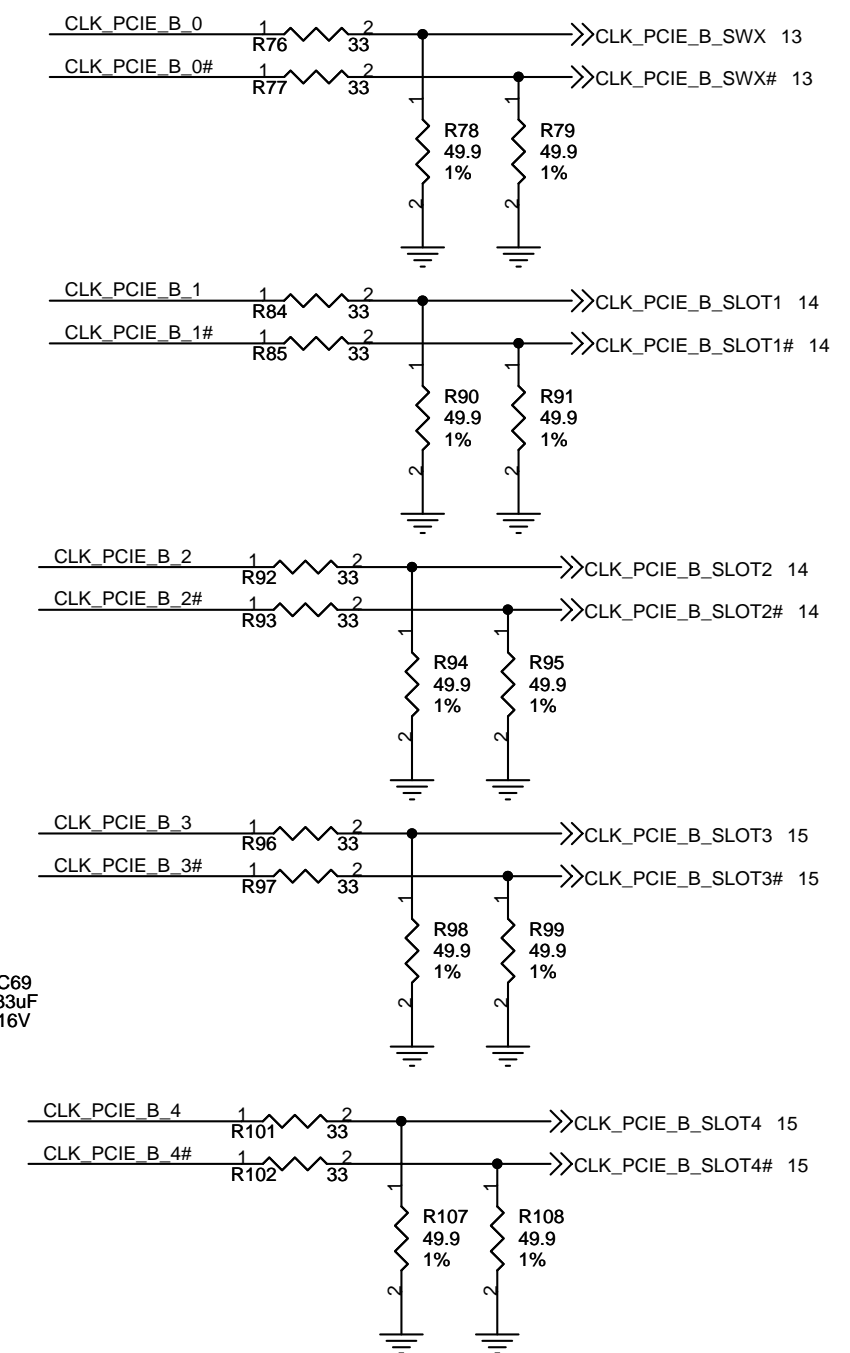

Power sequencing circuit for PCIe Switch

<Variant Name>		
B	See updates 3-25-08 thru 4-9-08	04/09/08 CA
A	See updates 2-26-08	02/26/08 CA
Rev	Description / ECN	Date
Title		APPLIED DATA SYSTEMS, INC. 10260 Old Columbia Rd, Suite G Columbia, MD 21046 1-800-541-2003
Size	Document Number 640122-300R	Rev B
Date:	Monday, April 14, 2008	Sheet 12 of 33



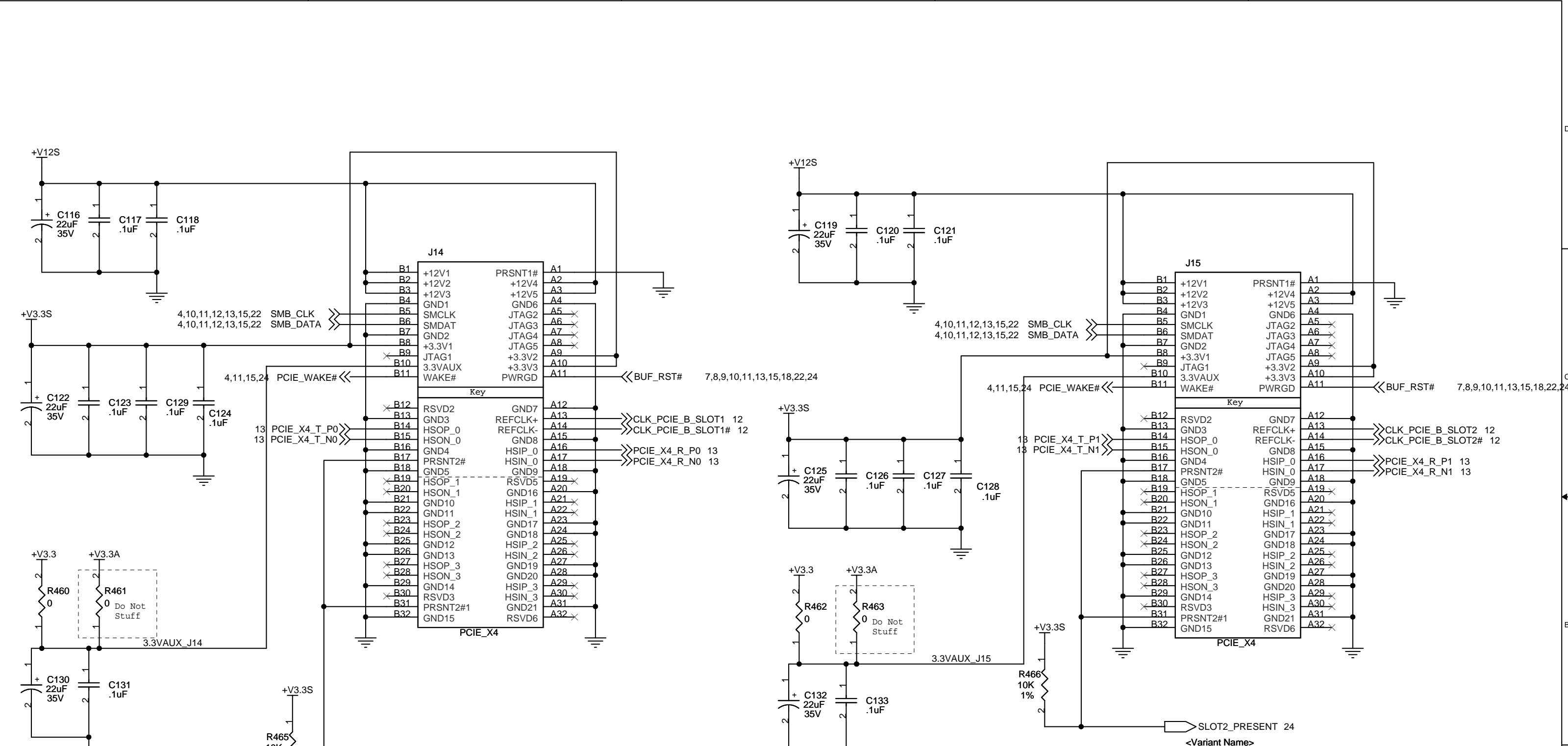

Rev	Description / ECN	Date	Ini.
B	See updates 3-25-08 thru 4-9-08	04/09/08	CA
A	See updates 2-26-08	02/26/08	CA
Rev	Description / ECN	Date	Ini.
Title		APPLIED DATA SYSTEMS, INC. 10260 Old Columbia Rd, Suite G Columbia, MD 21046 1-800-541-2003	
Size	Document Number	640122-300R	Rev B
Date:	Monday, April 14, 2008	Sheet	14 of 33

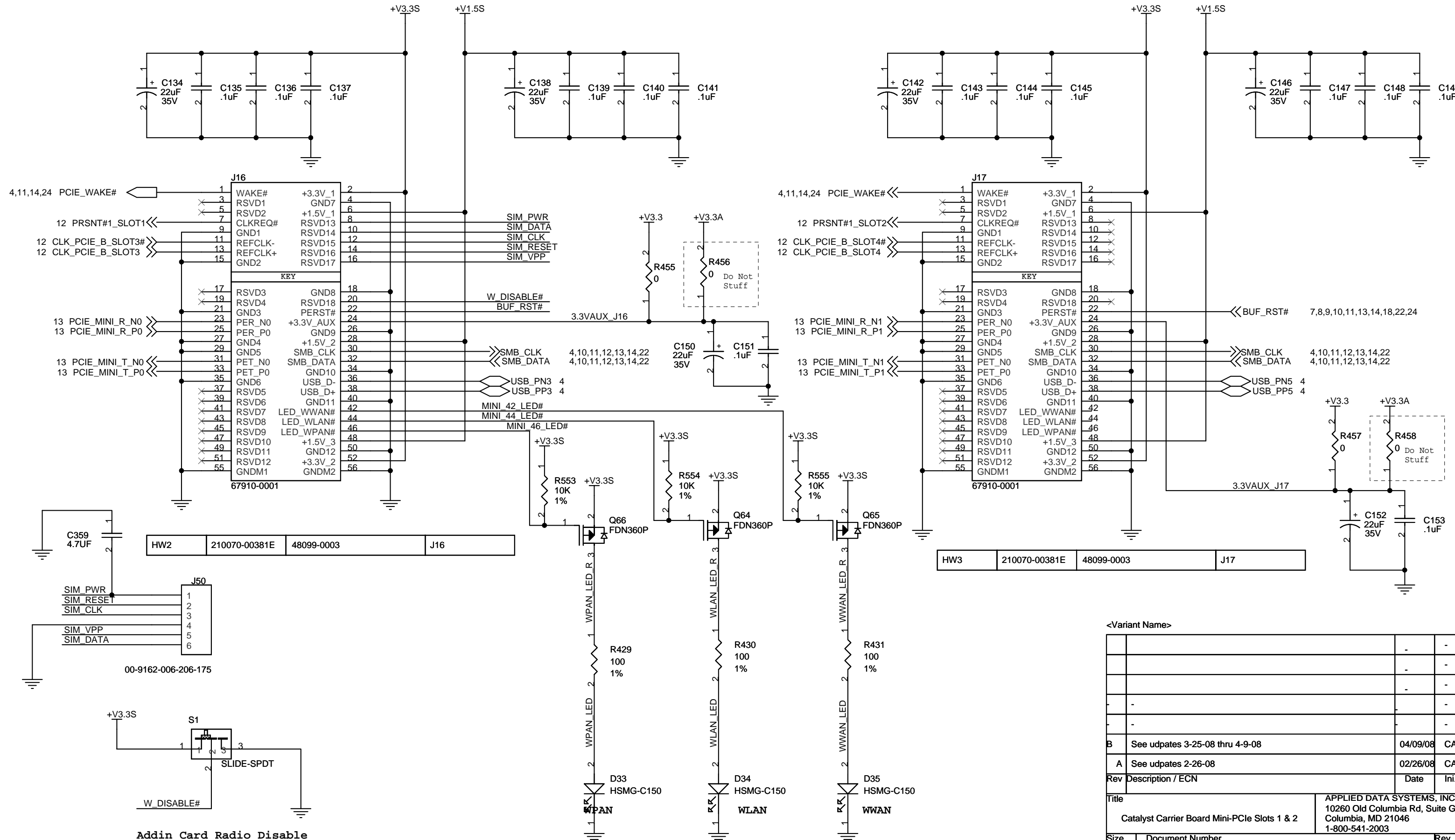

00-9162-006-206-175

Addin Card Radio Disable

<Variant Name>			
		-	-
		-	-
		-	-
		-	-
		-	-
B	See updates 3-25-08 thru 4-9-08	04/09/08	CA
A	See updates 2-26-08	02/26/08	CA
Rev	Description / ECN	Date	Ini.
Title		APPLIED DATA SYSTEMS, INC.	
Catalyst Carrier Board Mini-PCle Slots 1 & 2		10260 Old Columbia Rd, Suite G Columbia, MD 21046 1-800-541-2003	
Size	Document Number	Rev	
	640122-300R	B	
Date:	Monday, April 14, 2008	Sheet	15 of 33



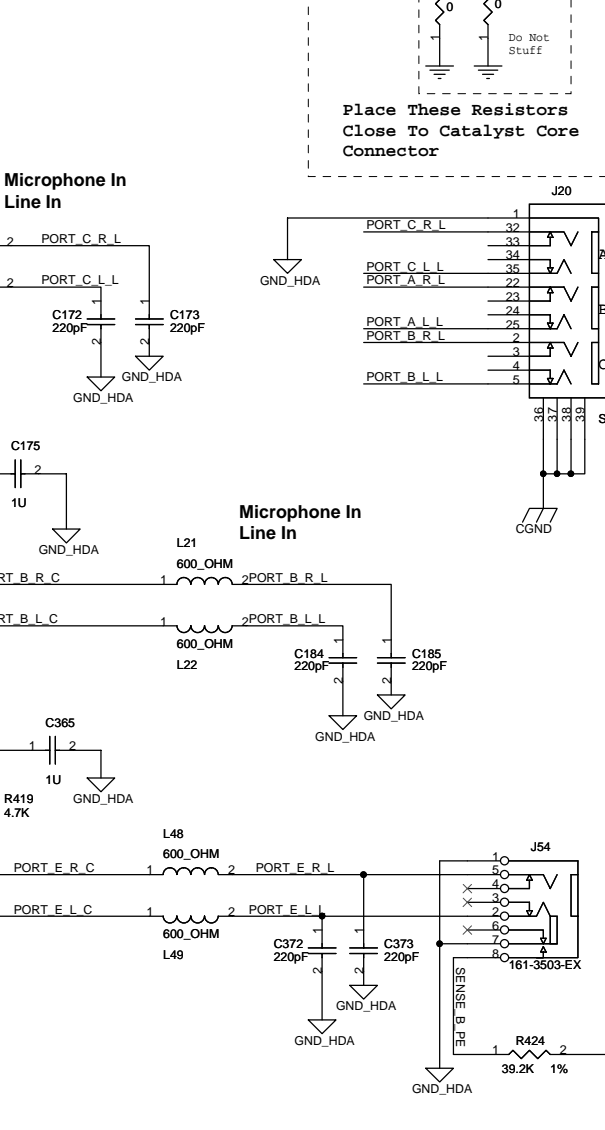
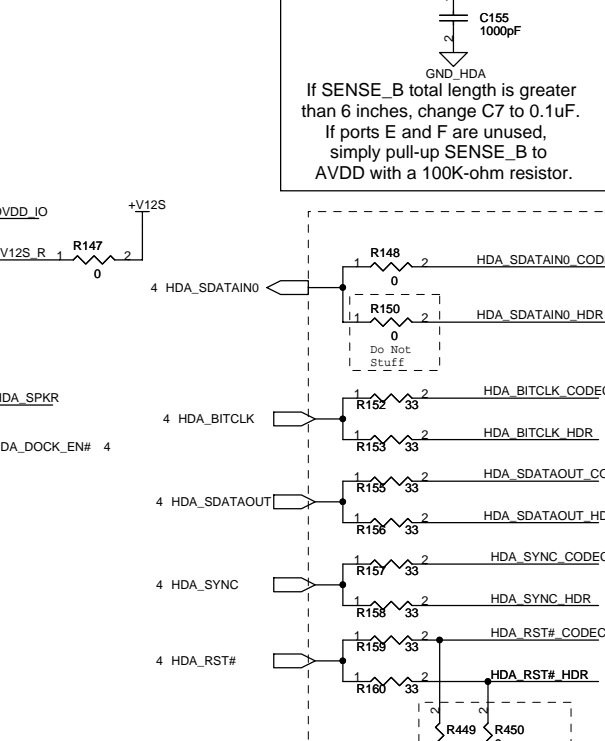
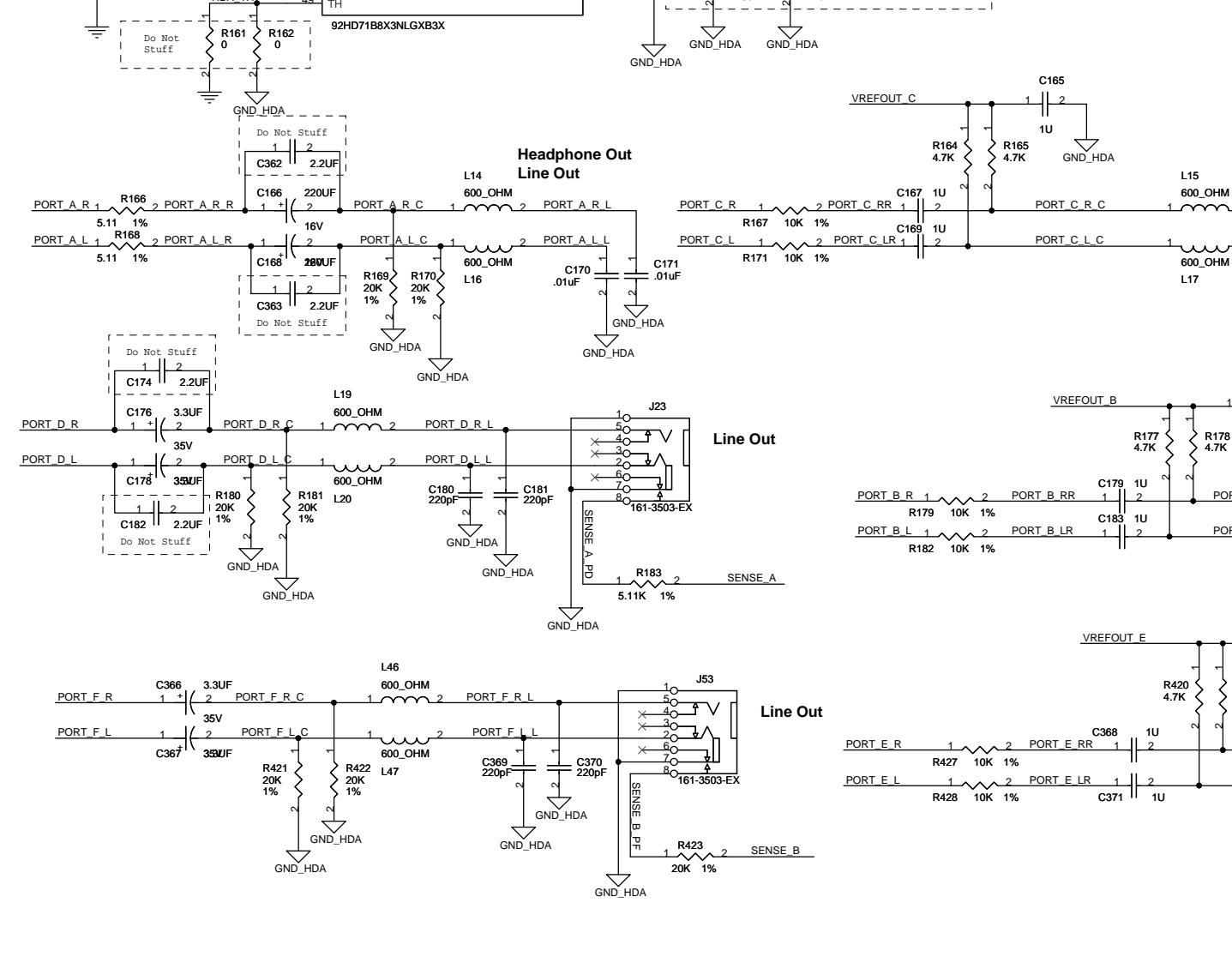
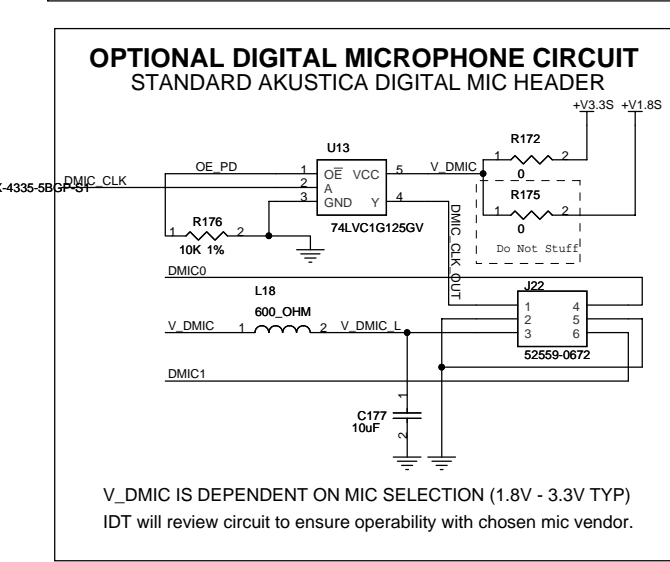
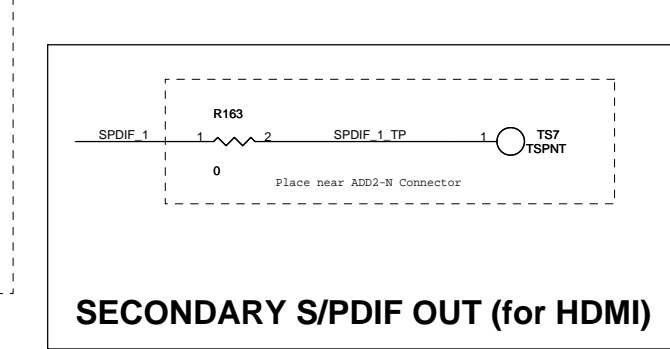
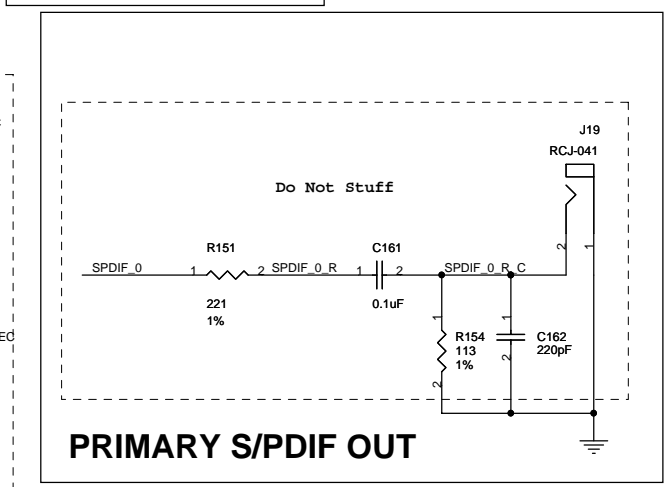
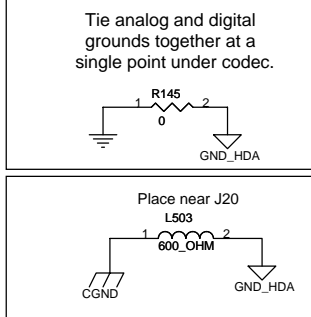
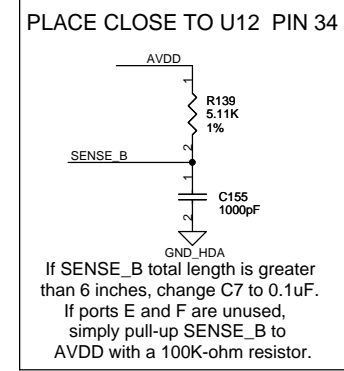
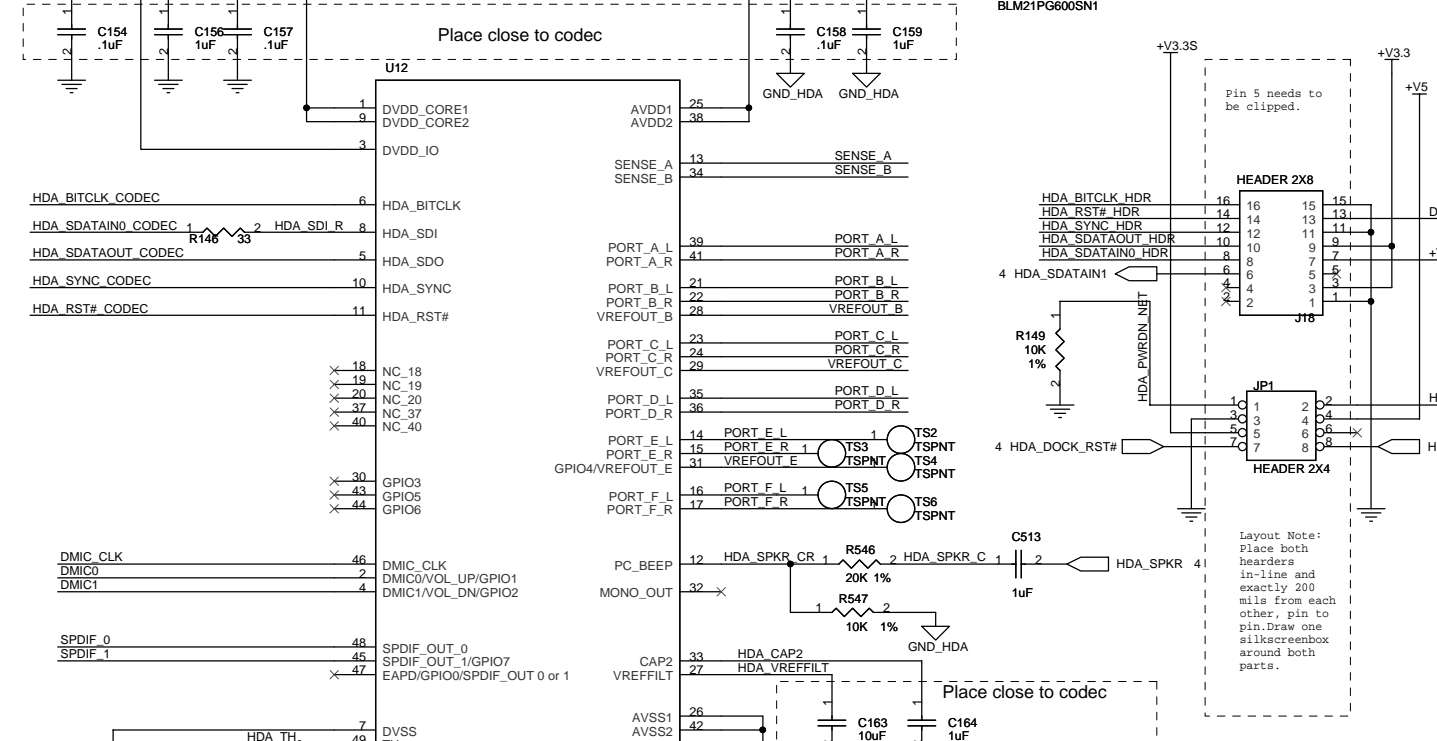
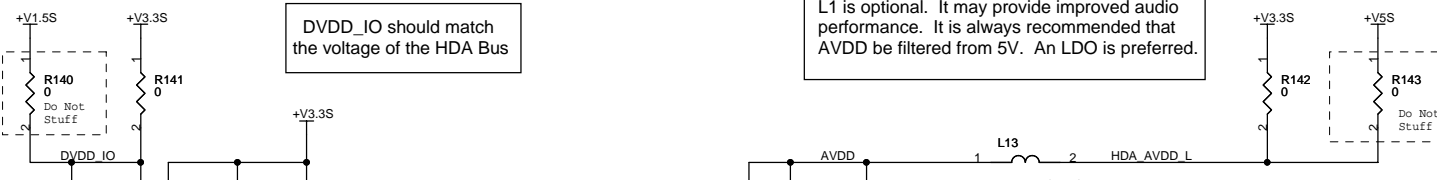

Rev	Description / ECN	Date	Ini.
B	See updates 3-25-08 thru 4-9-08	04/09/08	CA
A	See updates 2-26-08	02/26/08	CA
Rev	Description / ECN	Date	Ini.
Title		APPLIED DATA SYSTEMS, INC. 10260 Old Columbia Rd, Suite G Columbia, MD 21046 1-800-541-2003	
Size	Document Number	640122-300R	Rev
Date	Monday, April 14, 2008	Sheet	16 of 33

TS\_CTRL\_+V5 is output from LM3526 with +5 volt input.

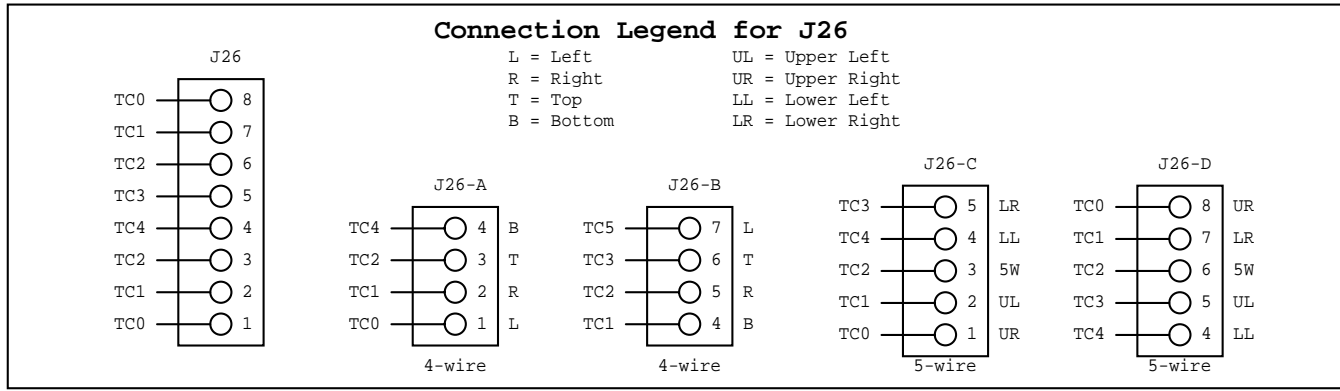
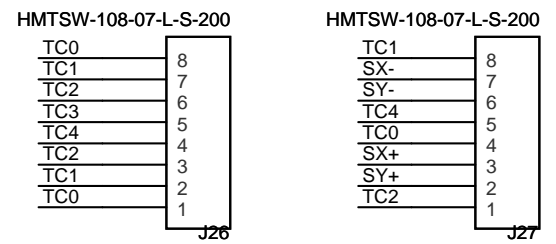
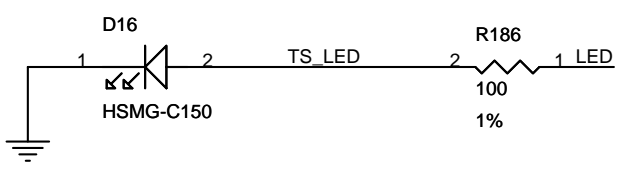
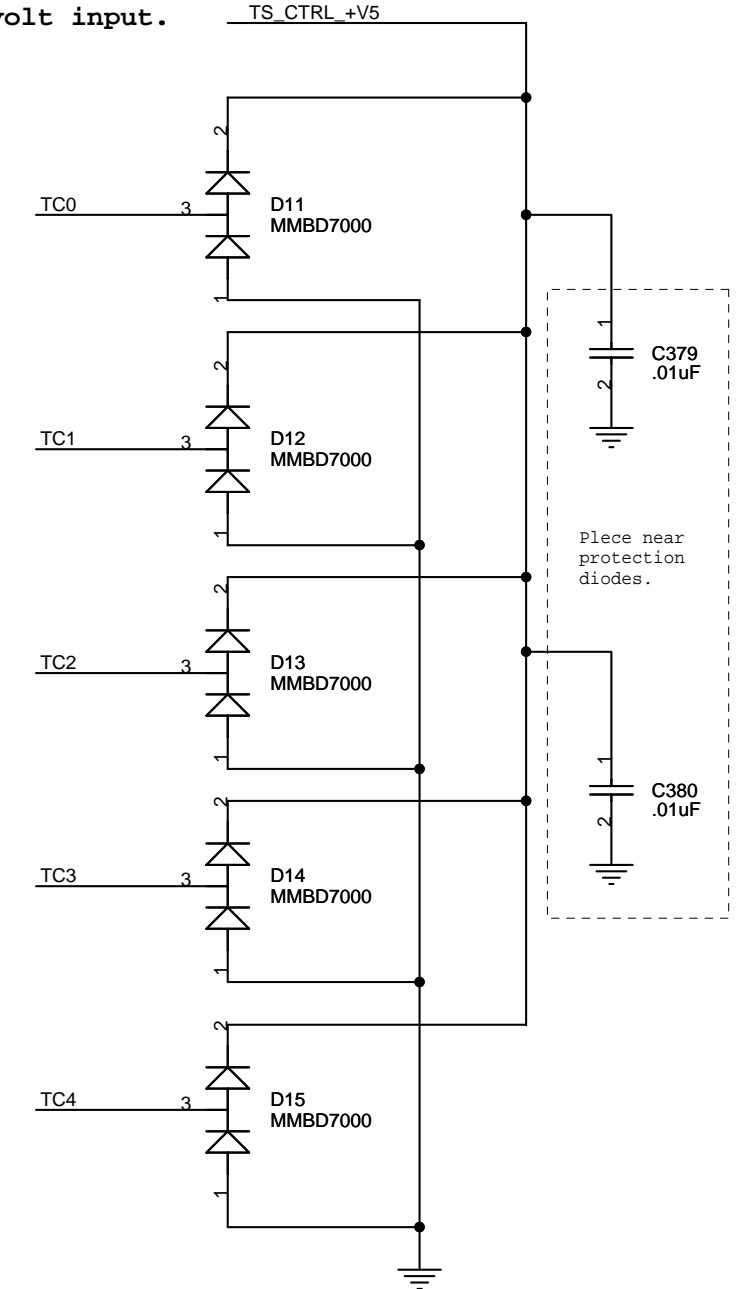
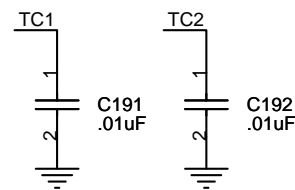
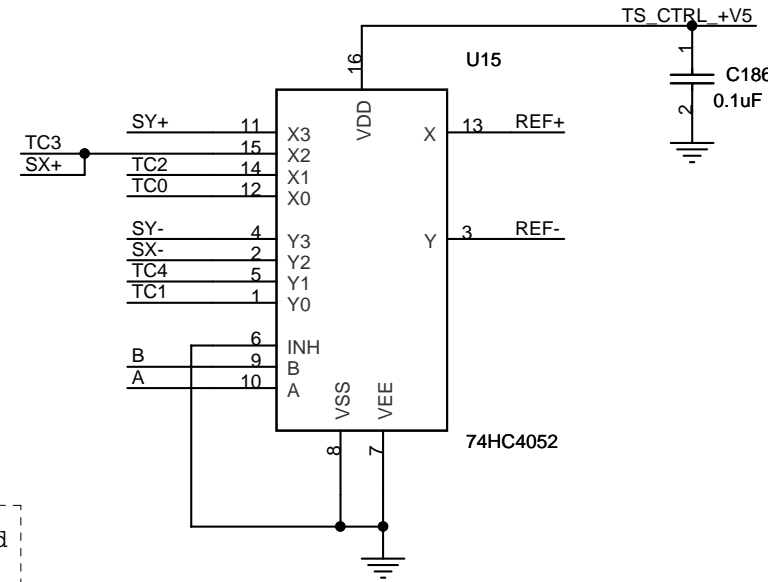
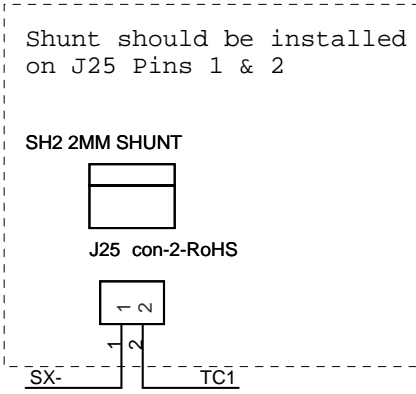
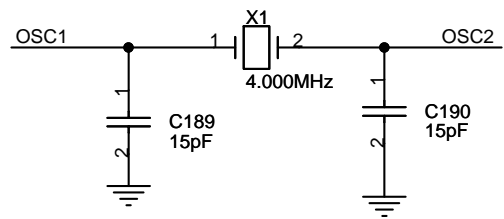
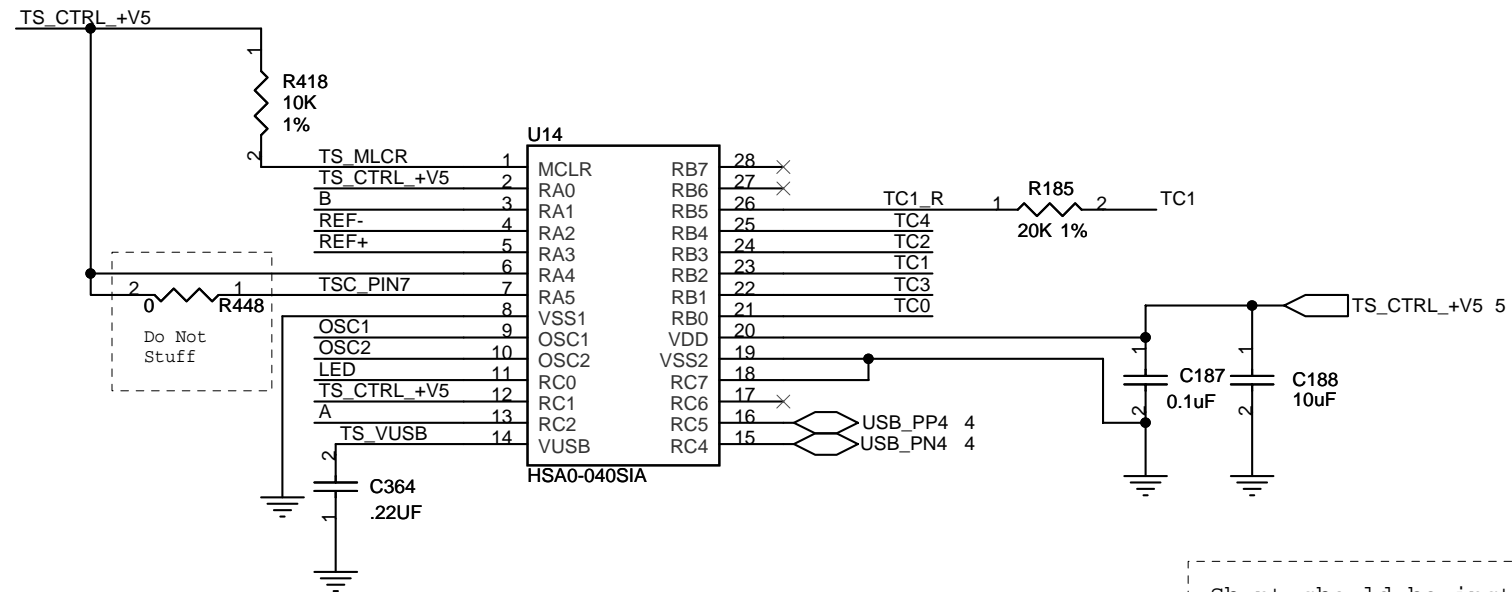

<Variant Name>		
B	See updates 3-25-08 thru 4-9-08	04/09/08 CA
A	See updates 2-26-08	02/26/08 CA
Rev	Description / ECN	Date
Title		APPLIED DATA SYSTEMS, INC.
Catalyst Carrier Board Touch Screen Controller		10260 Old Columbia Rd, Suite G Columbia, MD 21046 1-800-541-2003
Size	Document Number	Rev
	640122-300R	B
Date:	Monday, April 14, 2008	Sheet 17 of 33

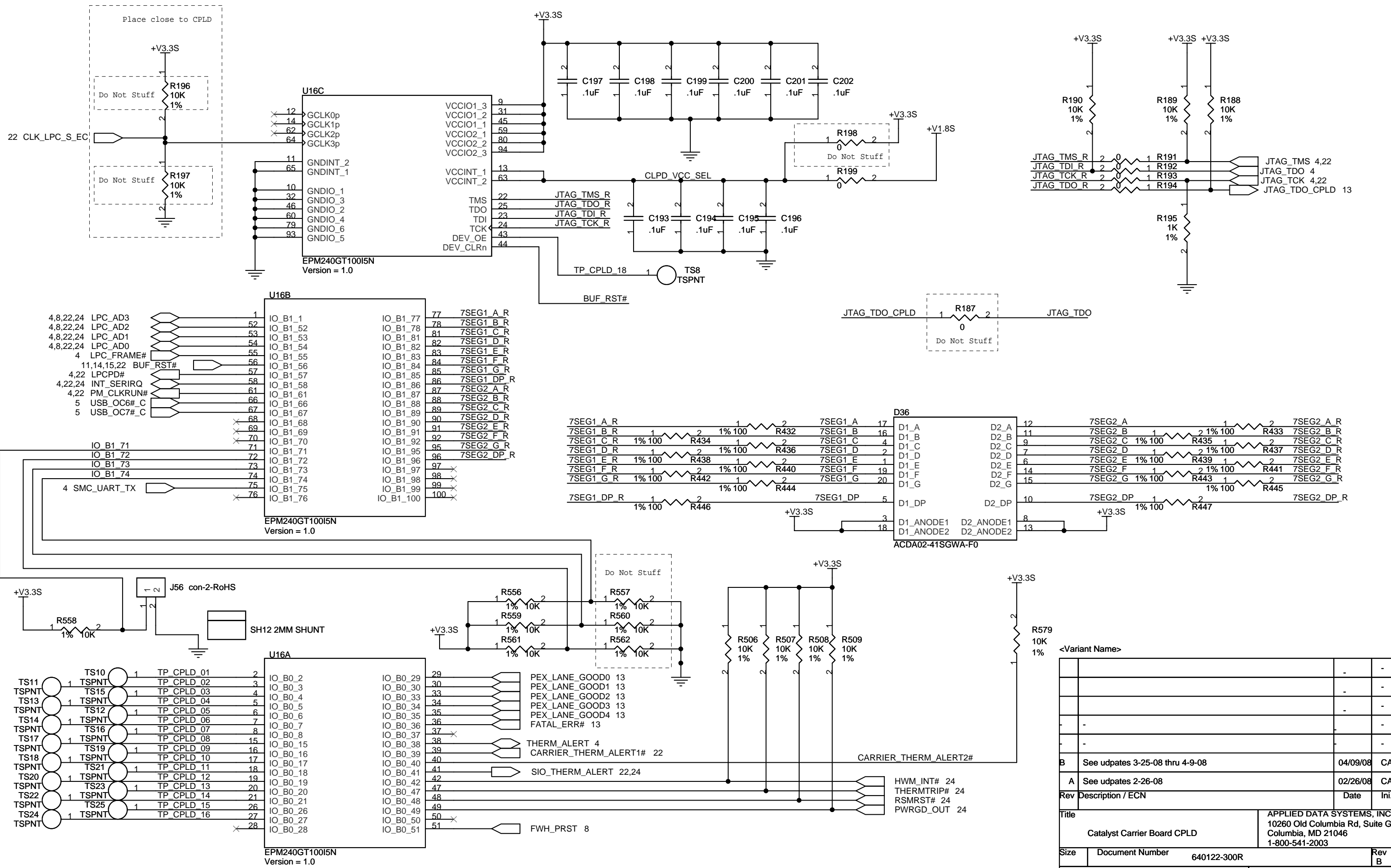

Rev	Description / ECN	Date	Ini.
B	See updates 3-25-08 thru 4-9-08	04/09/08	CA
A	See updates 2-26-08	02/26/08	CA
Rev	Description / ECN	Date	Ini.
Title		APPLIED DATA SYSTEMS, INC. 10260 Old Columbia Rd, Suite G Columbia, MD 21046 1-800-541-2003	
Size	Document Number	640122-300R	Rev B
Date:	Monday, April 14, 2008	Sheet	18 of 33

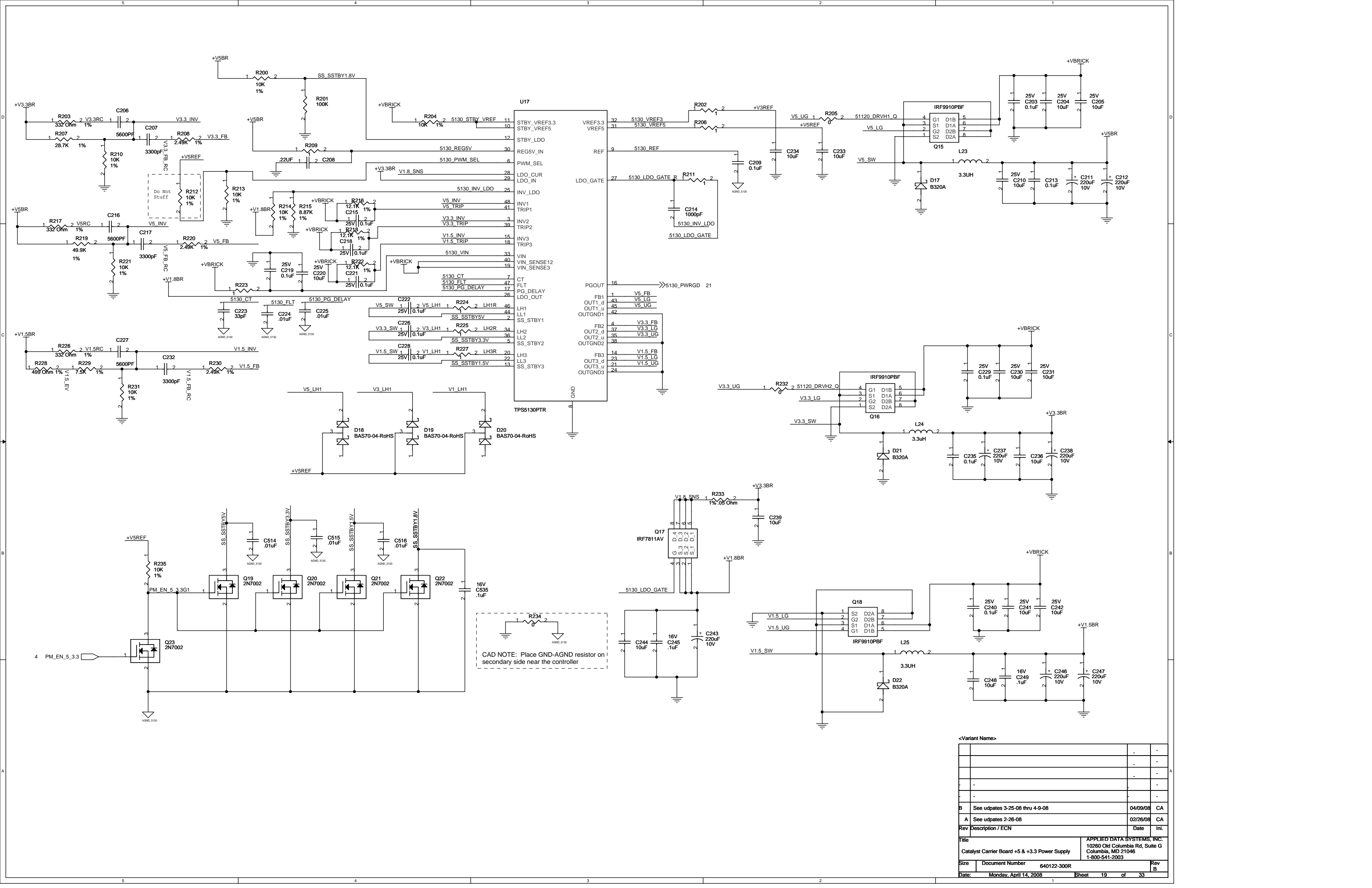

CAD NOTE: Place GND-AGND resistor on secondary side near the controller

Rev Description / ECN		
Rev	Date	Ini.
B	See updates 3-25-08 thru 4-9-08	04/09/08 CA
A	See updates 2-26-08	02/26/08 CA
Title		
Catalyst Carrier Board +5 & +3.3 Power Supply		APPLIED DATA SYSTEMS, INC. 10260 Old Columbia Rd, Suite G Columbia, MD 21046 1-800-541-2003
Size	Document Number	Rev
Date	Monday, April 14, 2008	B

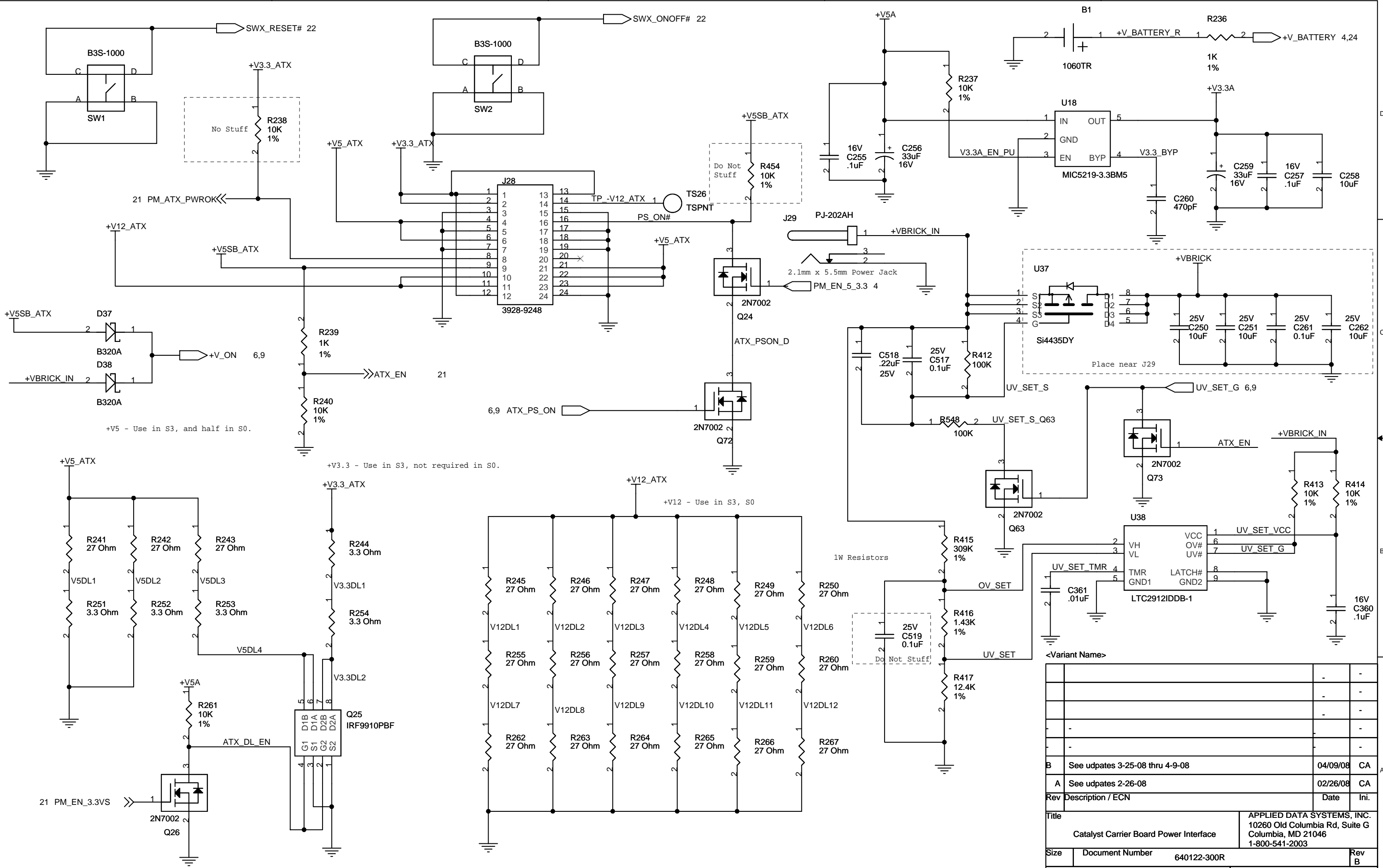

Rev	Description / ECN	Date	Ini.
B	See updates 3-25-08 thru 4-9-08	04/09/08	CA
A	See updates 2-26-08	02/26/08	CA
Rev	Description / ECN	Date	Ini.

Title		APPLIED DATA SYSTEMS, INC.	
Catalyst Carrier Board Power Interface		10260 Old Columbia Rd, Suite G Columbia, MD 21046 1-800-541-2003	
Size	Document Number	Rev	B
	640122-300R		
Date:	Monday, April 14, 2008	Sheet	20 of 33

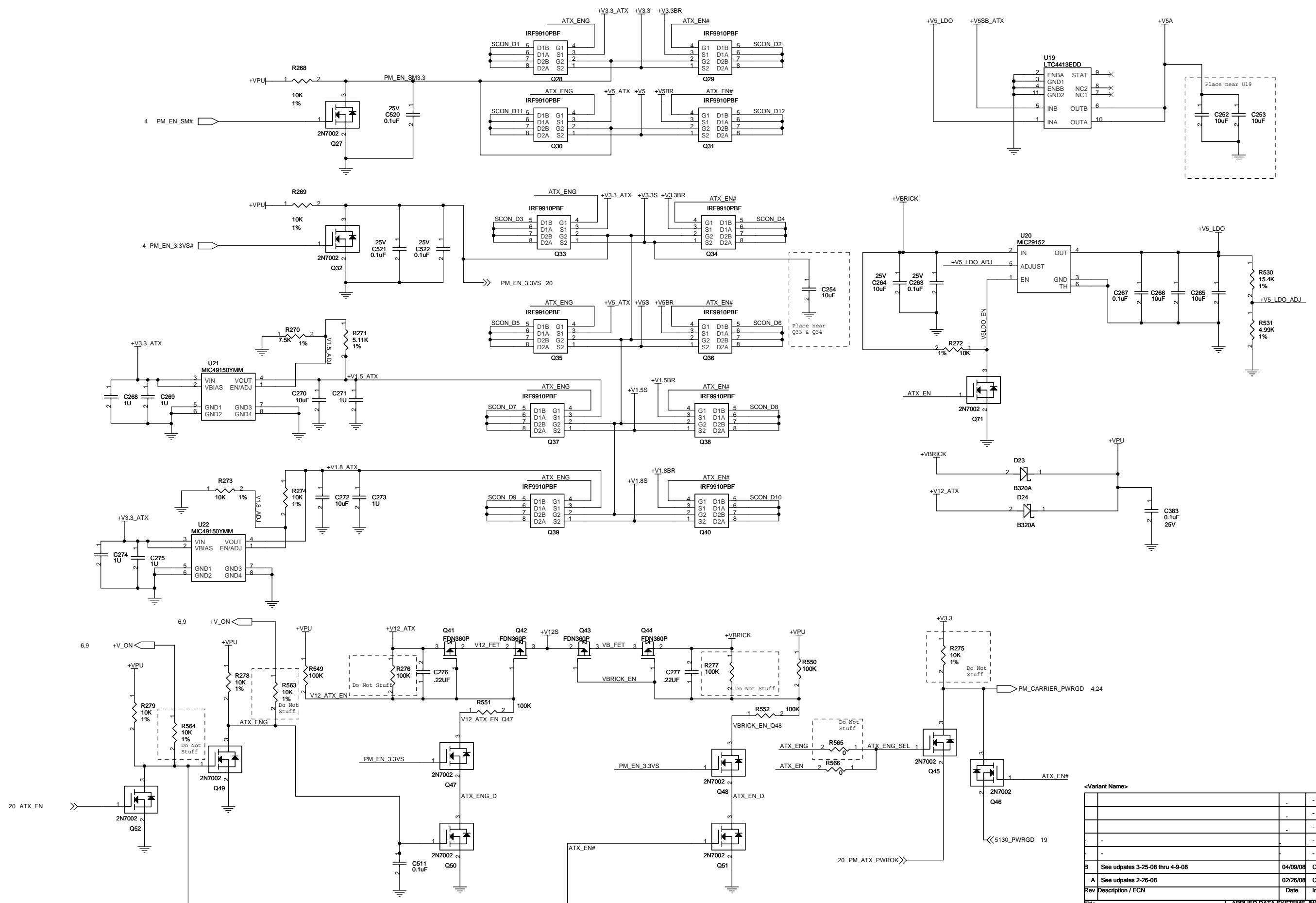

<Variant Name>			
B	See updates 3-25-08 thru 4-9-08	04/09/08	CA
A	See updates 2-26-08	02/26/08	CA
Rev	Description / ECN	Date	Ini.
Title		APPLIED DATA SYSTEMS, INC. 10260 Old Columbia Rd, Suite G Columbia, MD 21046 1-800-541-2003	
Size	Document Number	640122-300R	Rev B
Date:	Monday, April 14, 2008	Sheet	21 of 33



PS/2 Keyboard and Mouse Stacked Connector

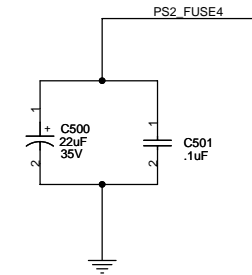
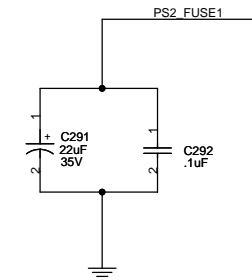
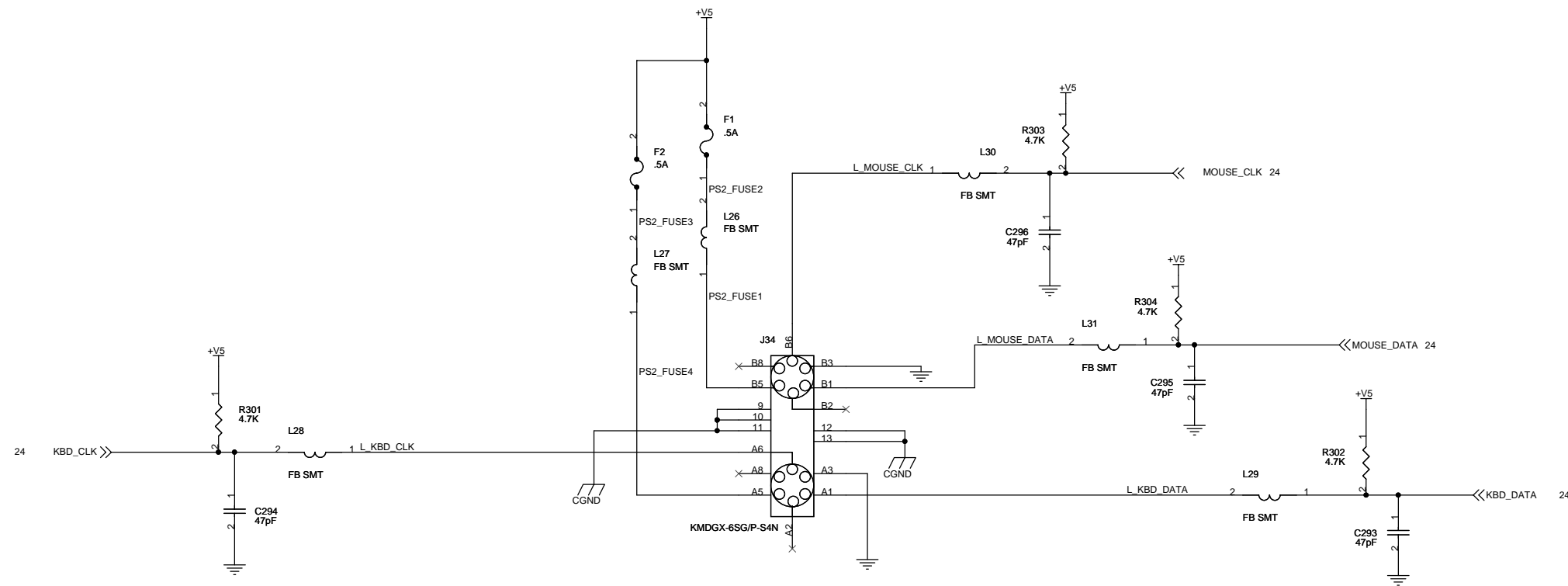

<Variant Name>

		-	-
		-	-
		-	-
		-	-
		-	-
B	See updates 3-25-08 thru 4-9-08	04/09/08	CA
A	See updates 2-26-08	02/26/08	CA
Rev	Description / ECN	Date	Ini.
Title		APPLIED DATA SYSTEMS, INC. 10260 Old Columbia Rd, Suite G Columbia, MD 21046 1-800-541-2003	
Size	Document Number	640122-300R	Rev B
Date:	Monday, April 14, 2008	Sheet	23 of 33



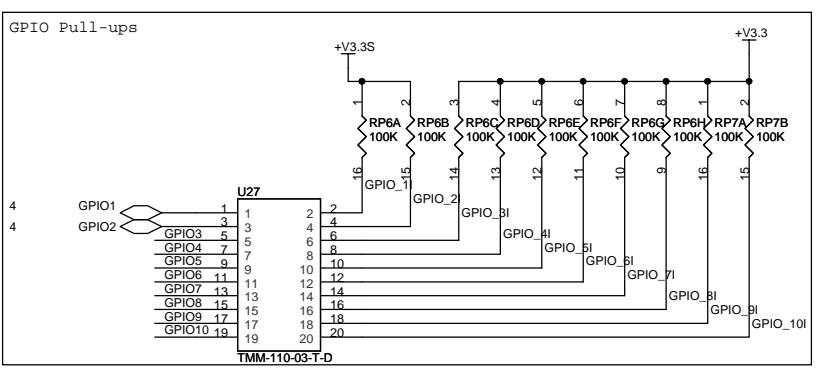
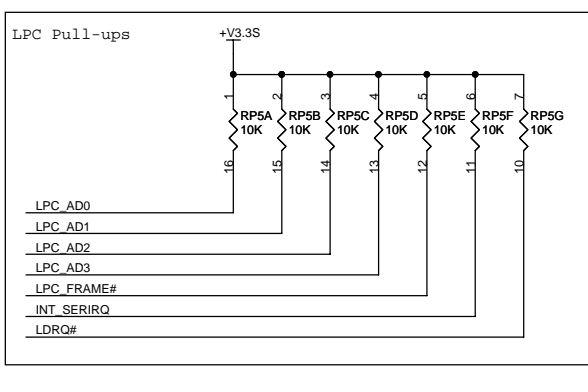
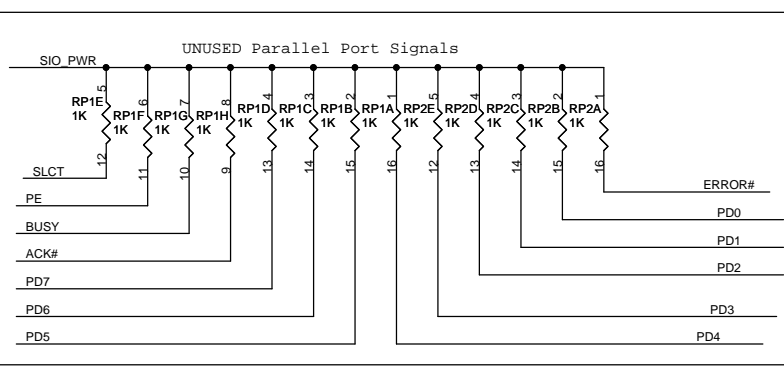
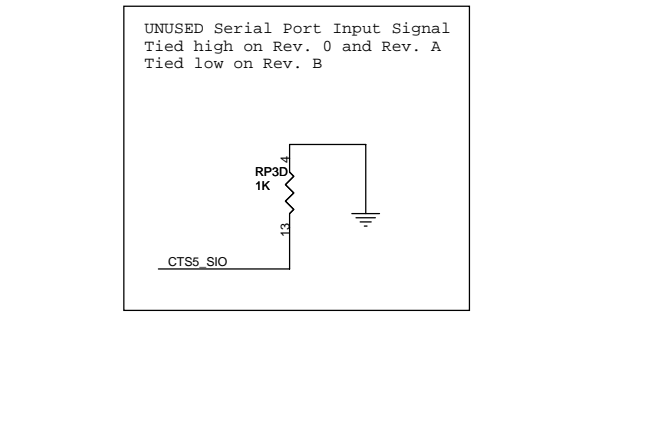
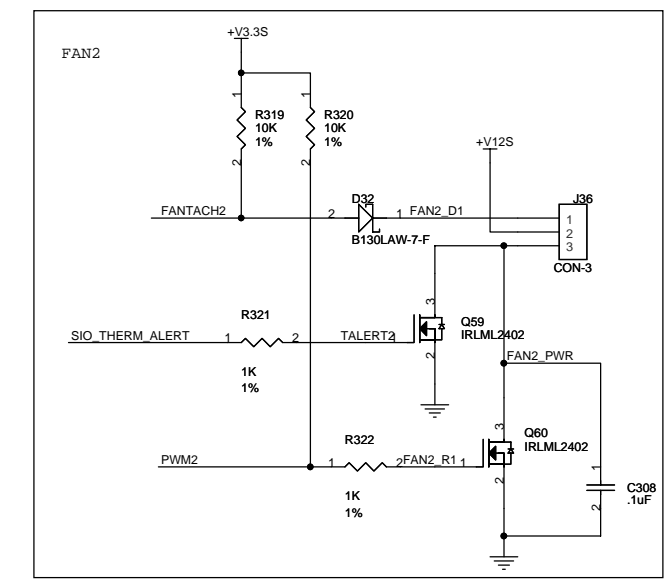
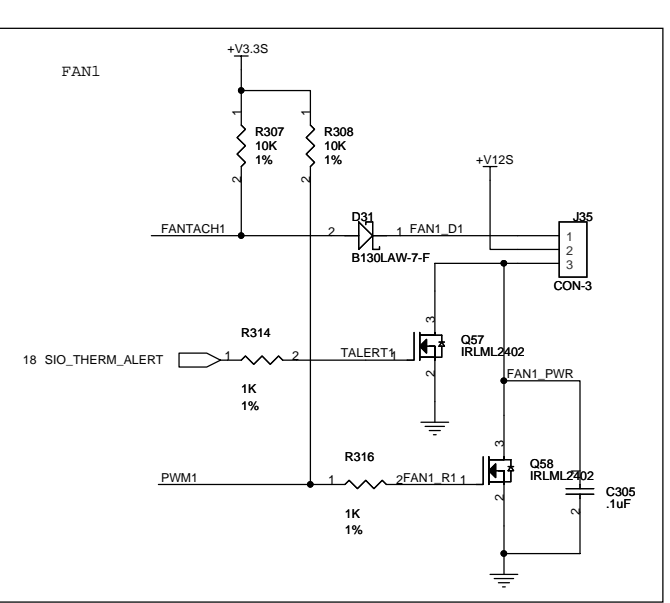
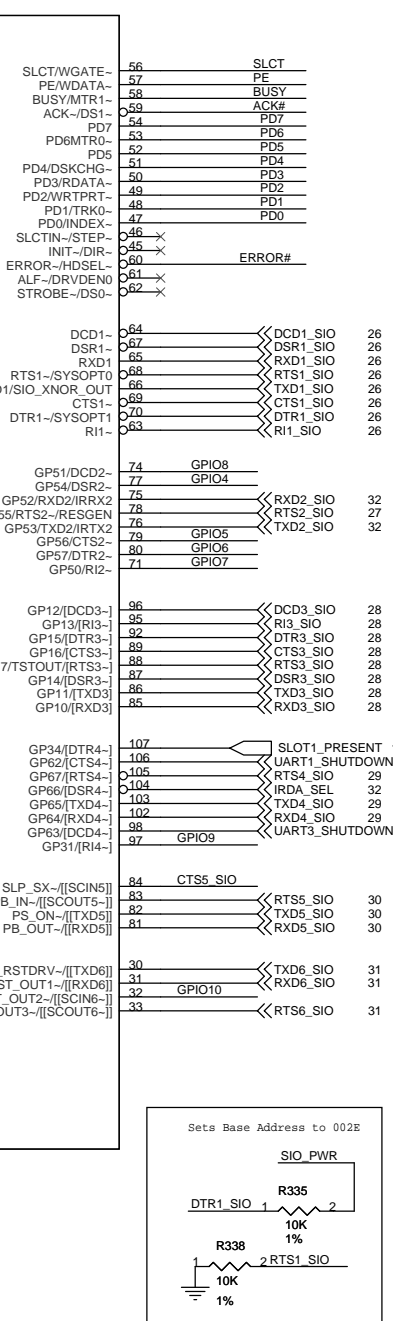
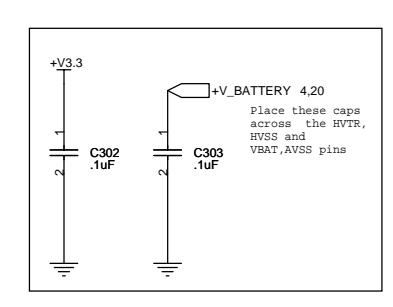
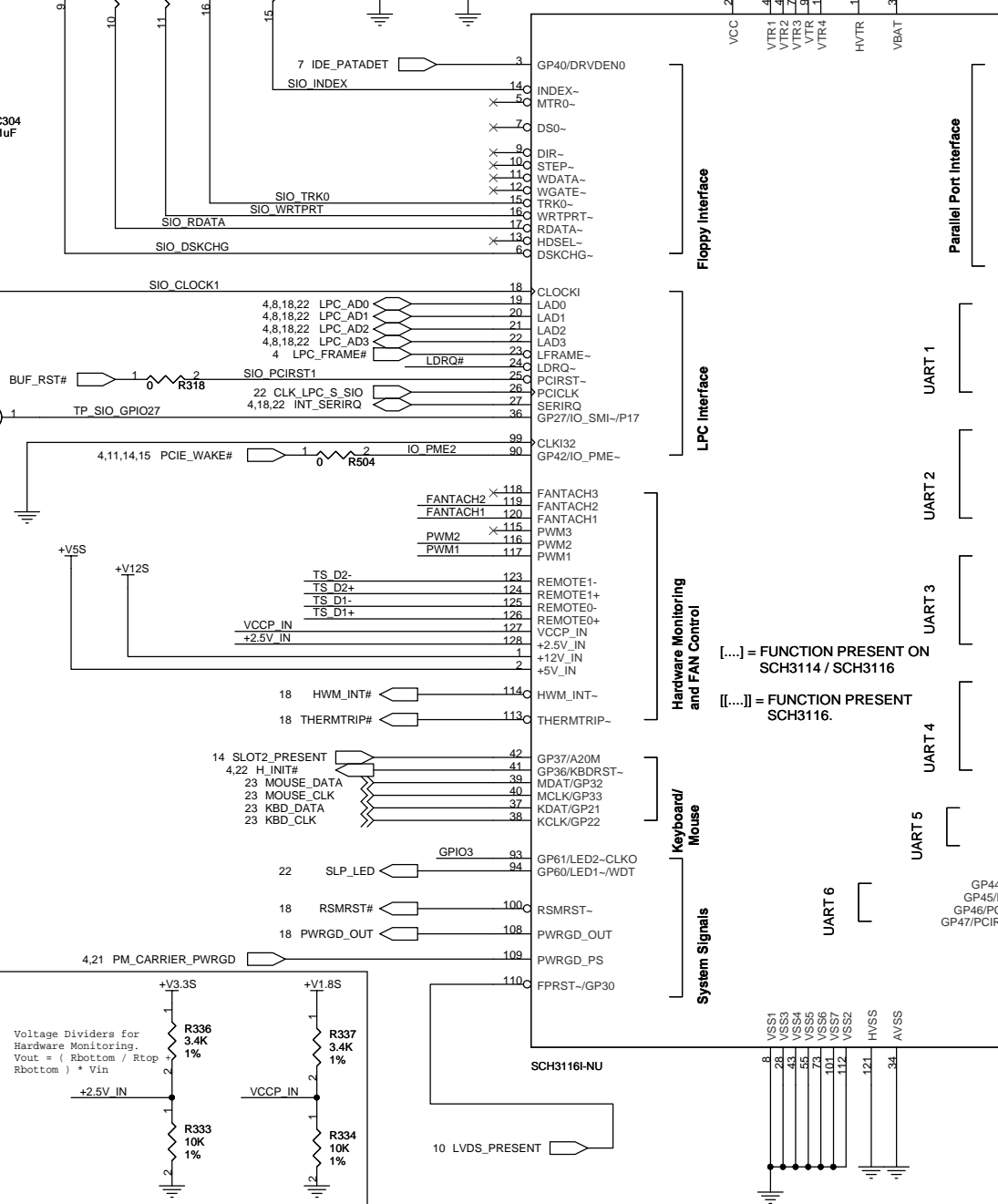
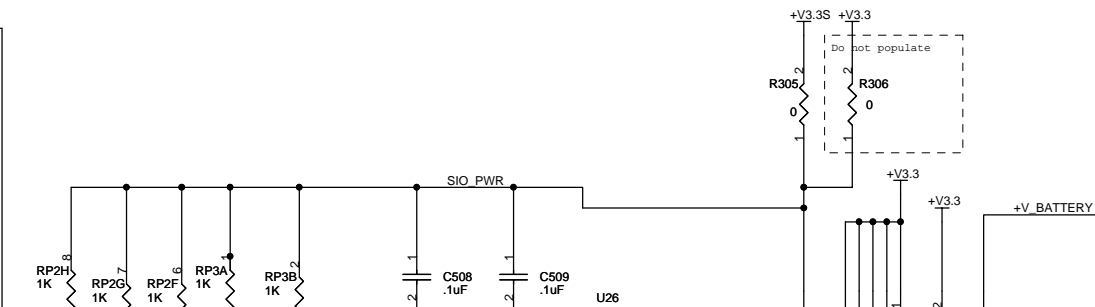
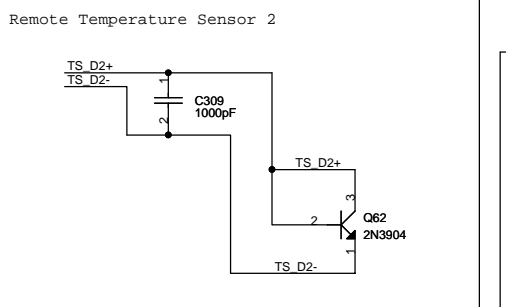
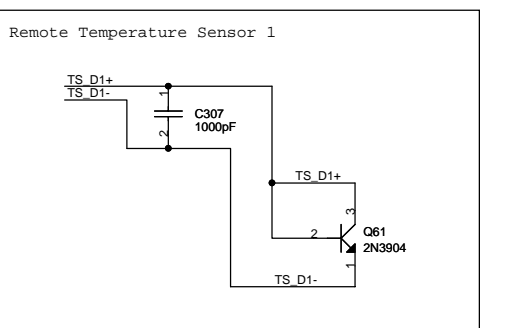
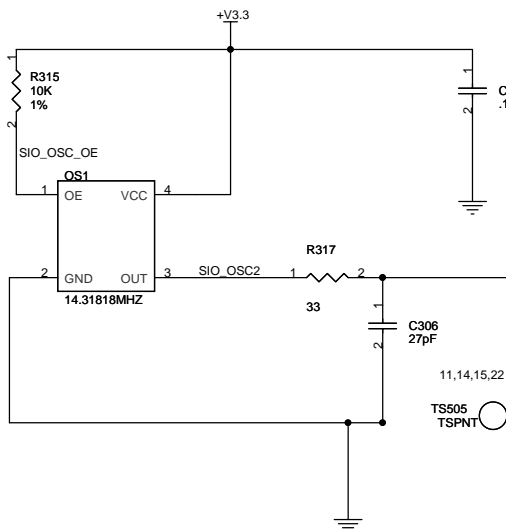
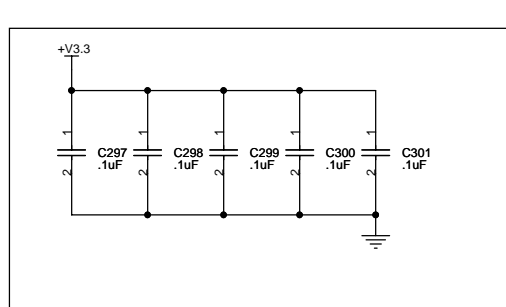

Rev	Description / ECN	Date	Ini.
B	See updates 3-25-08 thru 4-9-08	04/09/08	CA
A	See updates 2-26-08	02/26/08	CA
Rev	Description / ECN	Date	Ini.
Title		APPLIED DATA SYSTEMS, INC. 10260 Old Columbia Rd, Suite G Columbia, MD 21046 1-800-541-2003	
Size	Document Number	640122-300R	Rev
Date	Monday, April 14, 2008	Sheet	24 of 33

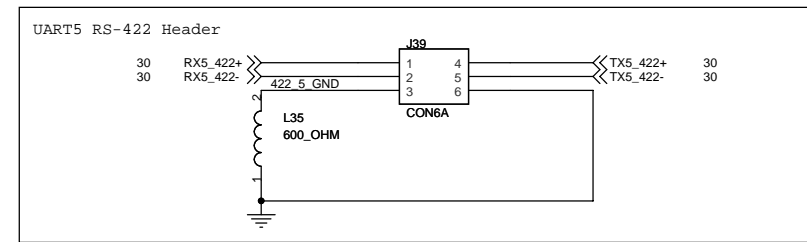
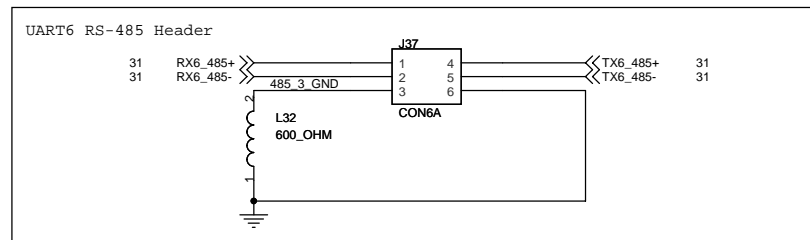
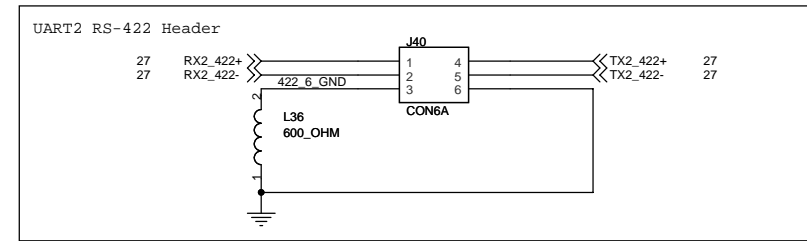
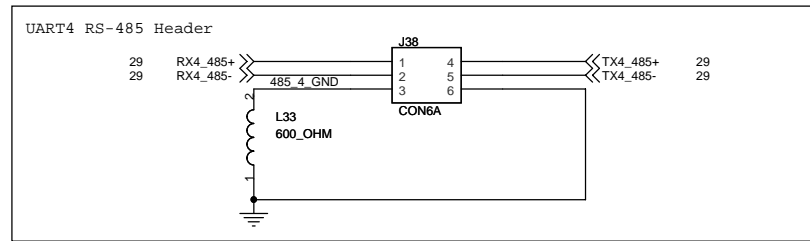
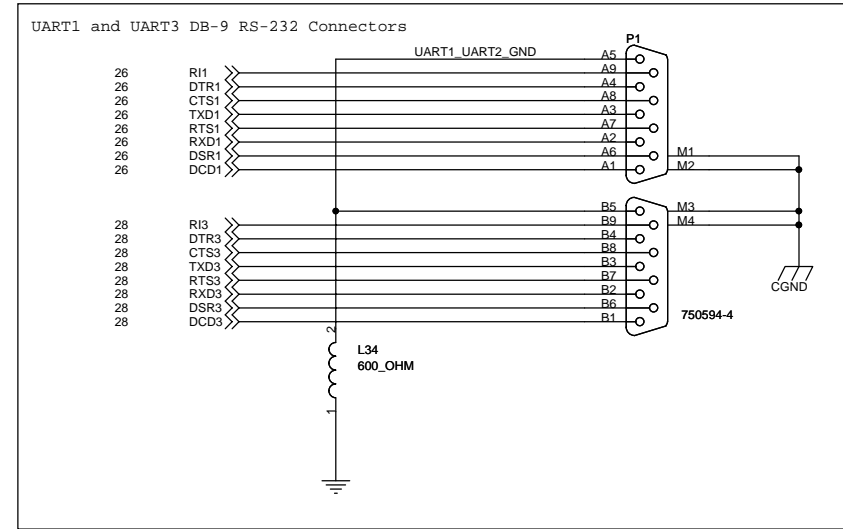

<Variant Name>

		-	-
		-	-
		-	-
		-	-
		-	-
B	See updates 3-25-08 thru 4-9-08	04/09/08	CA
A	See updates 2-26-08	02/26/08	CA
Rev	Description / ECN	Date	Ini.
Title		APPLIED DATA SYSTEMS, INC. 10260 Old Columbia Rd, Suite G Columbia, MD 21046 1-800-541-2003	
Size	Document Number	640122-300R	Rev
Date:	Monday, April 14, 2008	Sheet	25 of 33

RS-232 driver

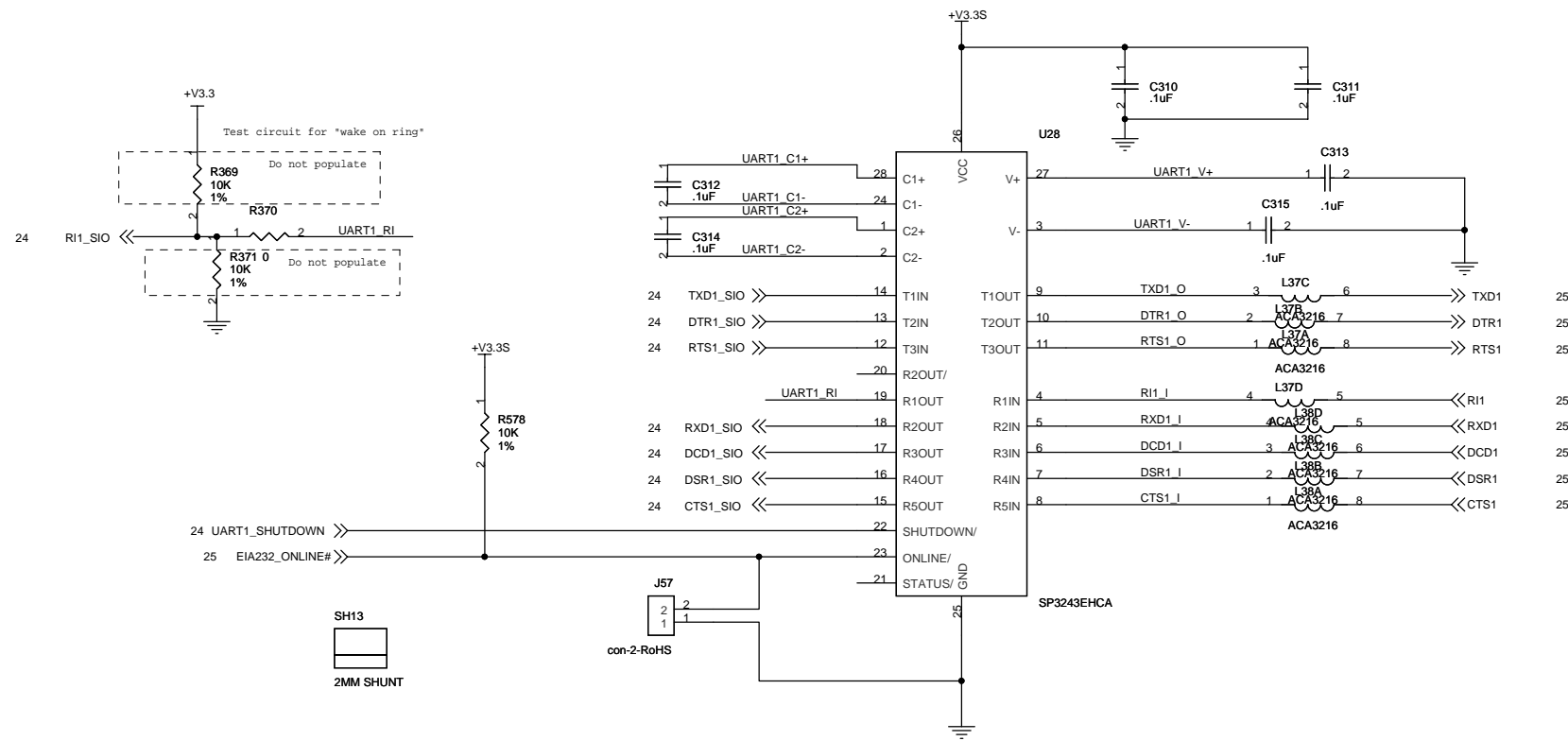

<Variant Name>

B	See updates 3-25-08 thru 4-9-08	04/09/08	CA
A	See updates 2-26-08	02/26/08	CA
Rev	Description / ECN	Date	Ini.
Title		APPLIED DATA SYSTEMS, INC. 10260 Old Columbia Rd, Suite G Columbia, MD 21046 1-800-541-2003	
Size	Document Number	640122-300R	Rev B
Date:	Monday, April 14, 2008	Sheet	26 of 33

RS-422 driver

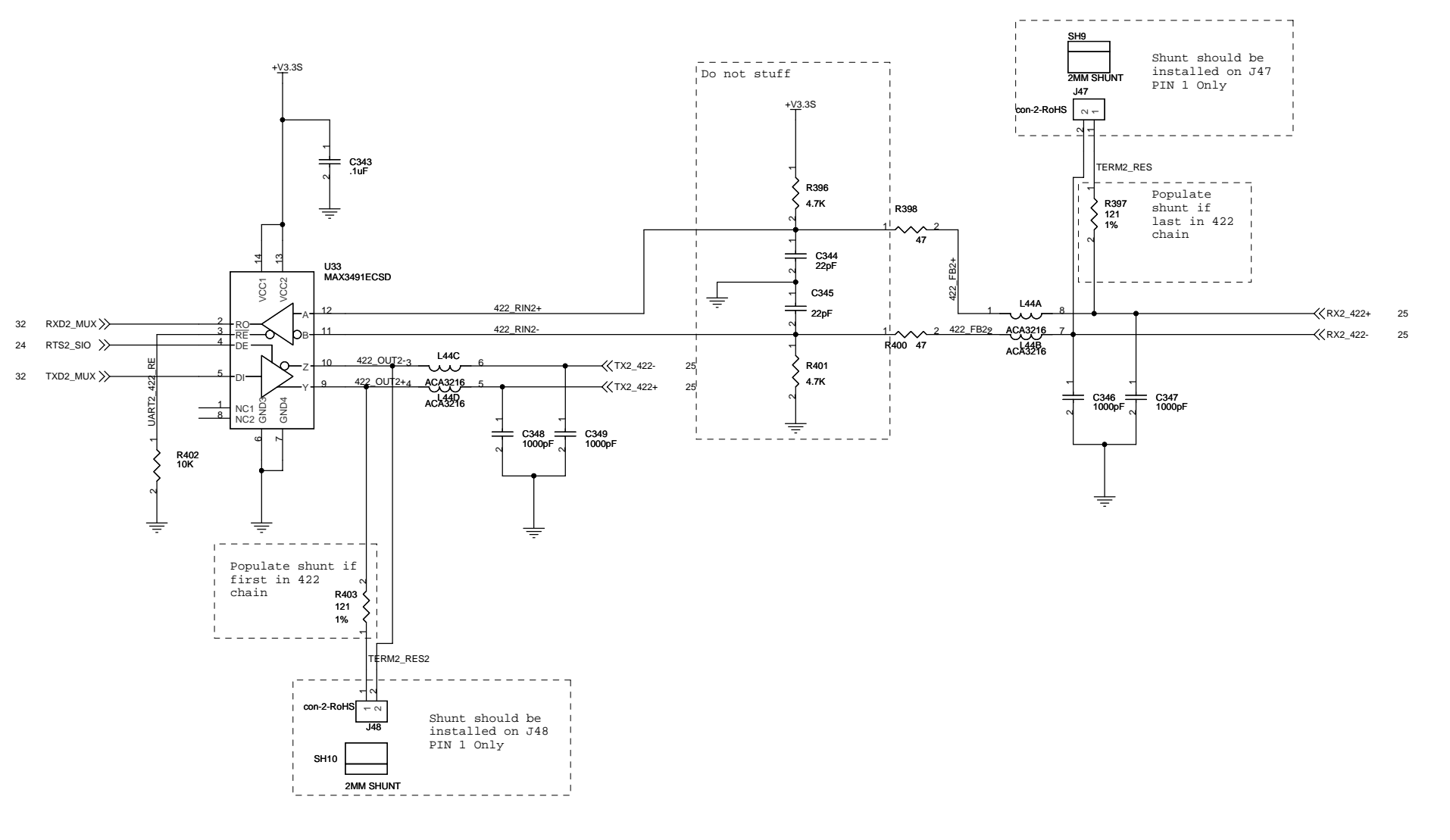

<Variant Name>

B	See updates 3-25-08 thru 4-9-08	04/09/08	CA
A	See updates 2-26-08	02/26/08	CA
Rev	Description / ECN	Date	Ini.
Title		APPLIED DATA SYSTEMS, INC. 10260 Old Columbia Rd, Suite G Columbia, MD 21046 1-800-541-2003	
Size	Document Number	640122-300R	Rev B
Date:	Monday, April 14, 2008	Sheet	27 of 33

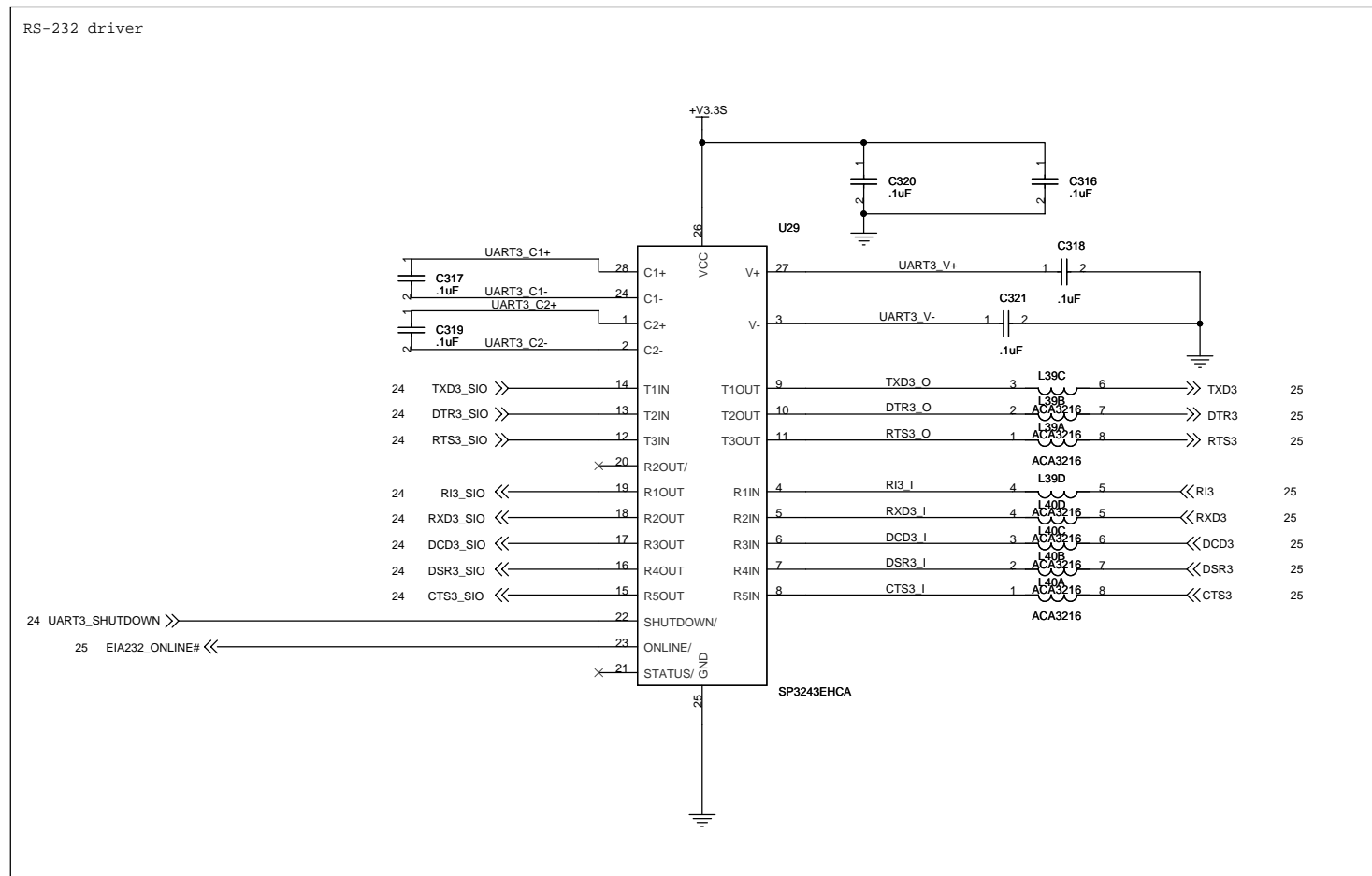

<Variant Name>

		-	-
		-	-
		-	-
		-	-
		-	-
B	See updates 3-25-08 thru 4-9-08	04/09/08	CA
A	See updates 2-26-08	02/26/08	CA
Rev	Description / ECN	Date	Ini.
Title		APPLIED DATA SYSTEMS, INC. 10260 Old Columbia Rd, Suite G Columbia, MD 21046 1-800-541-2003	
Size	Document Number	Rev	
	640122-300R	B	
Date:	Monday, April 14, 2008	Sheet	28 of 33

RS-485 driver

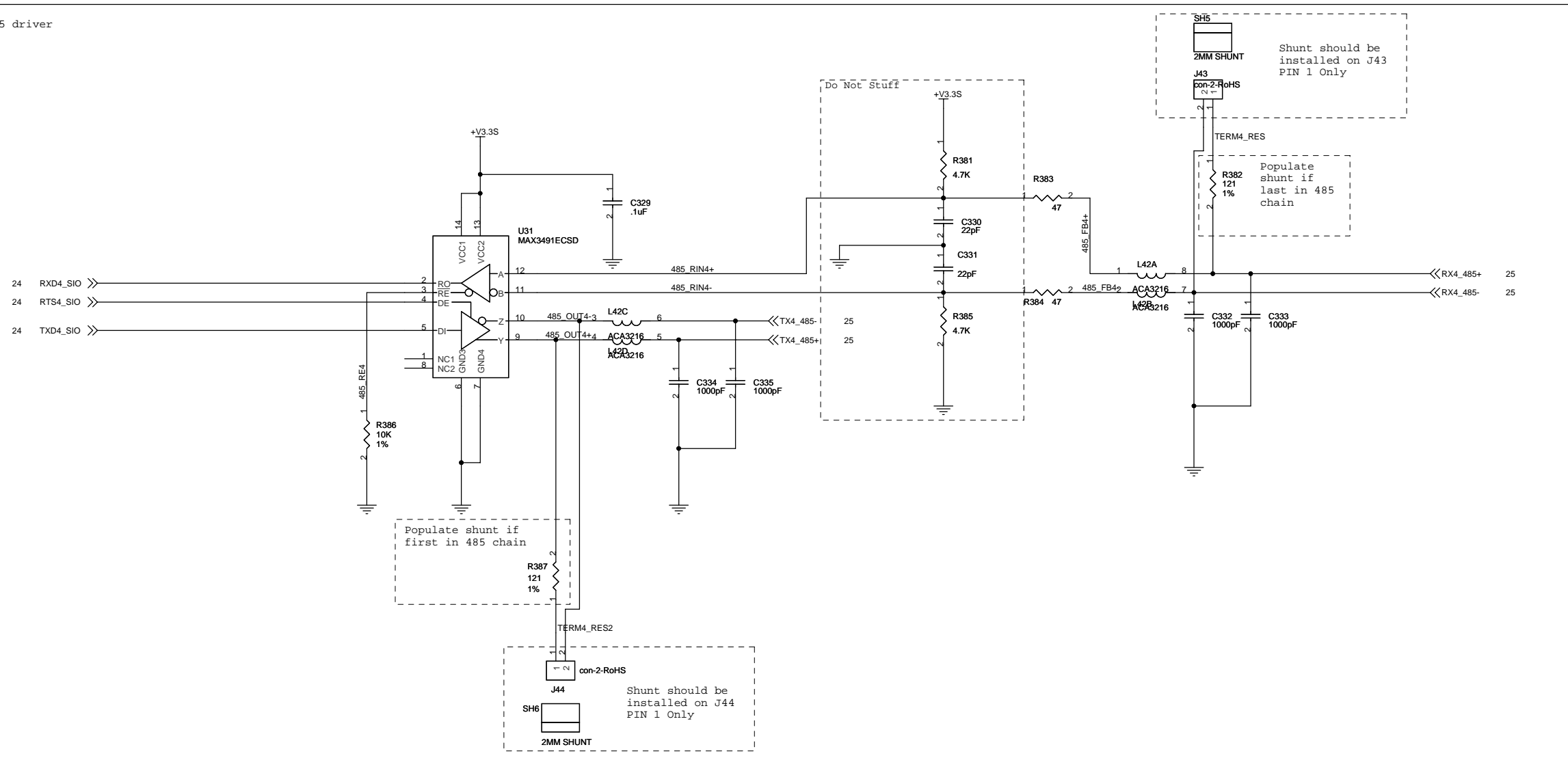

<Variant Name>

B	See updates 3-25-08 thru 4-9-08	04/09/08	CA
A	See updates 2-26-08	02/26/08	CA
Rev	Description / ECN	Date	Ini.
Title		APPLIED DATA SYSTEMS, INC. 10260 Old Columbia Rd, Suite G Columbia, MD 21046 1-800-541-2003	
Size	Document Number	640122-300R	Rev B
Date:	Monday, April 14, 2008	Sheet	29 of 33

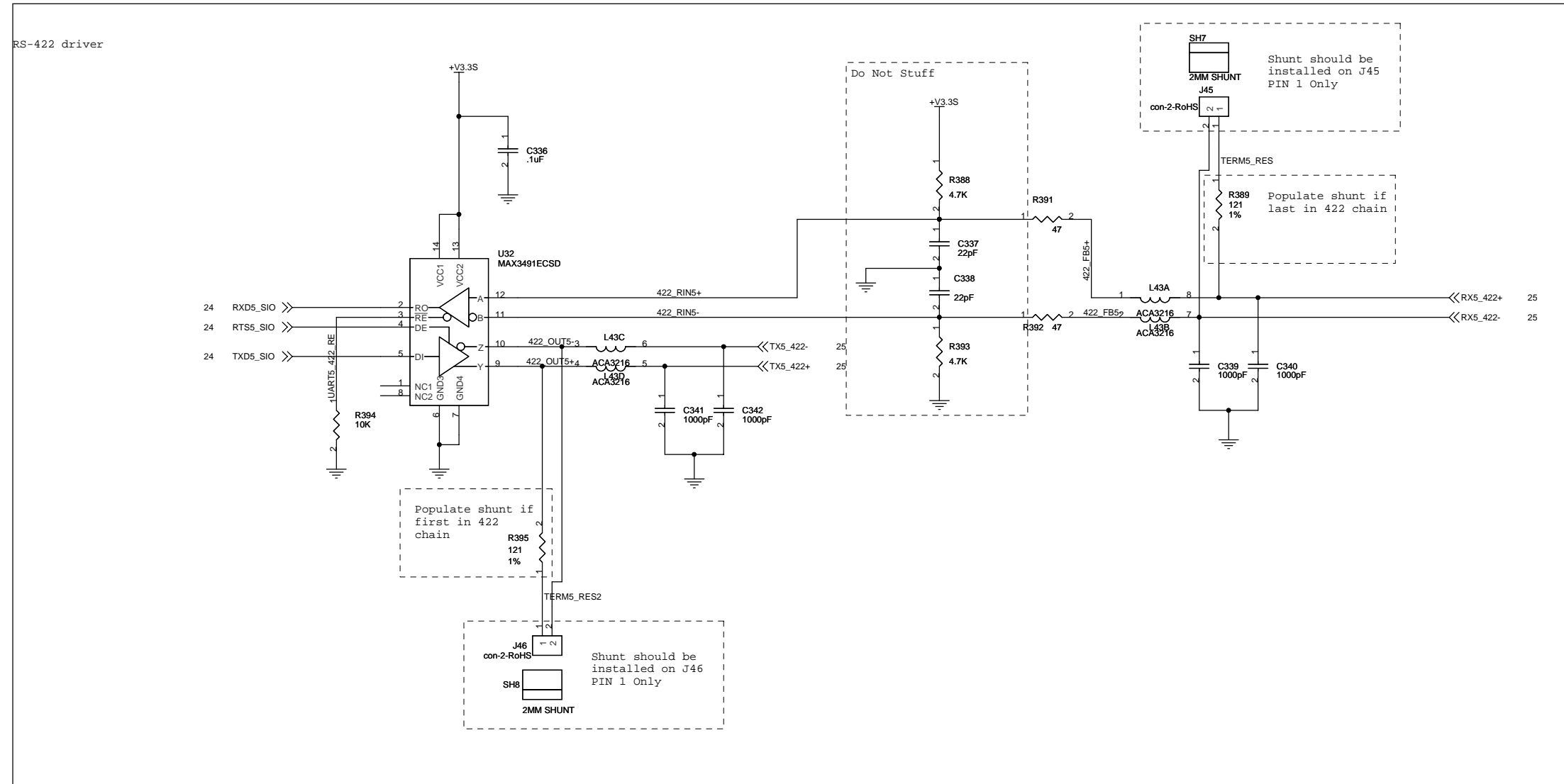

<Variant Name>

B	See updates 3-25-08 thru 4-9-08	04/09/08	CA
A	See updates 2-26-08	02/26/08	CA
Rev	Description / ECN	Date	Ini.
Title		APPLIED DATA SYSTEMS, INC. 10260 Old Columbia Rd, Suite G Columbia, MD 21046 1-800-541-2003	
Size	Document Number	Rev	
	640122-300R	B	
Date:	Monday, April 14, 2008	Sheet	30 of 33

RS-485 driver

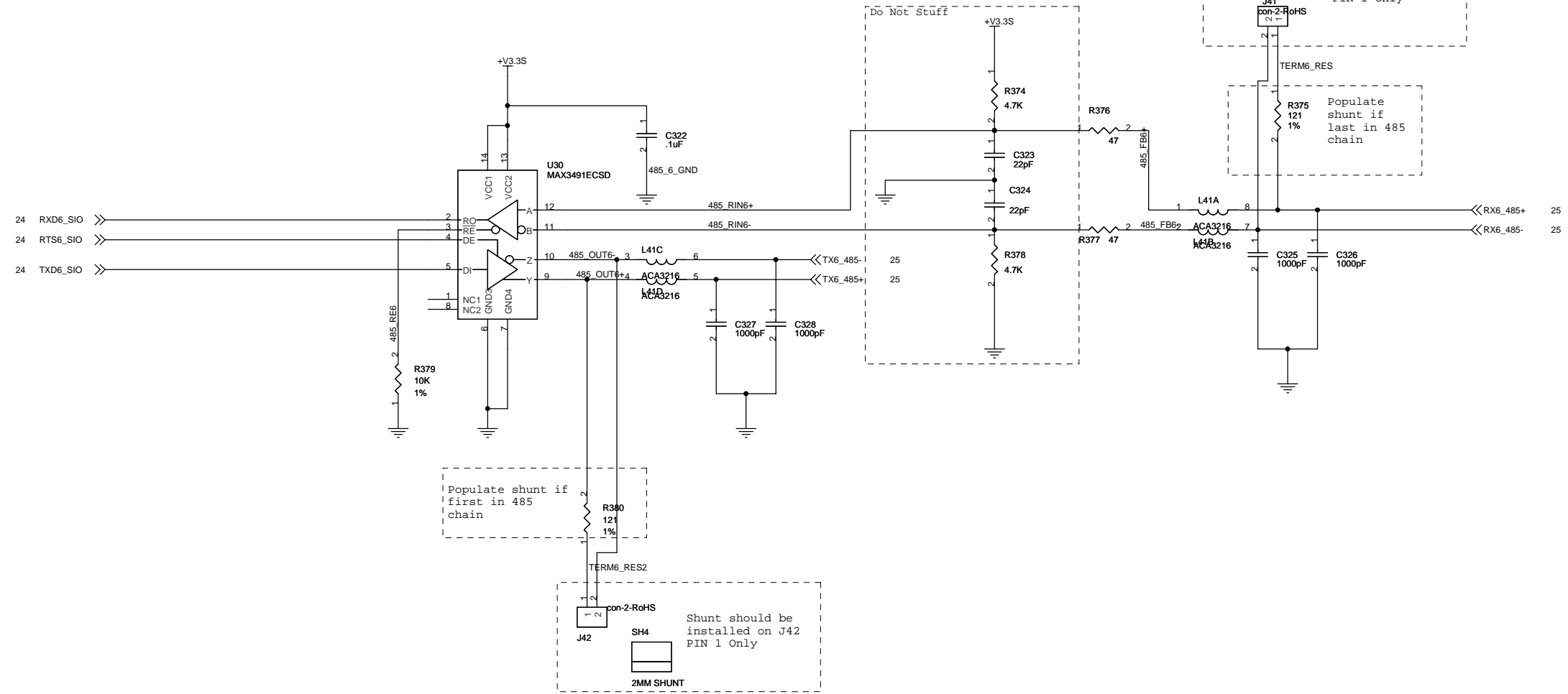

<Variant Name>

B	See updates 3-25-08 thru 4-9-08	04/09/08	CA
A	See updates 2-26-08	02/26/08	CA
Rev	Description / ECN	Date	Ini.
Title		APPLIED DATA SYSTEMS, INC.	
Catalyst Carrier Board UART3		10260 Old Columbia Rd, Suite G Columbia, MD 21046 1-800-541-2003	
Size	Document Number	640122-300R	Rev
Date:	Monday, April 14, 2008	Sheet	31 of 33



RS-232 driver

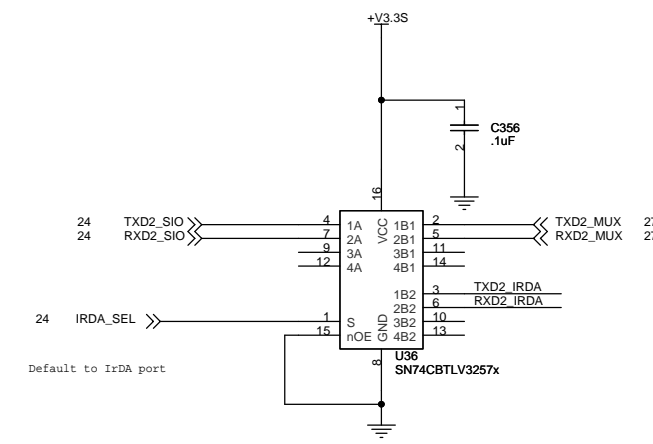
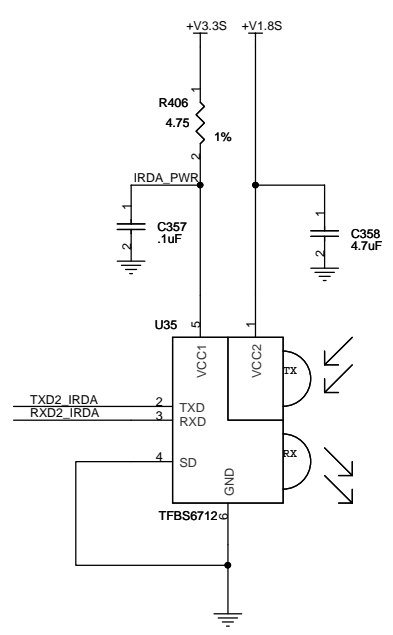
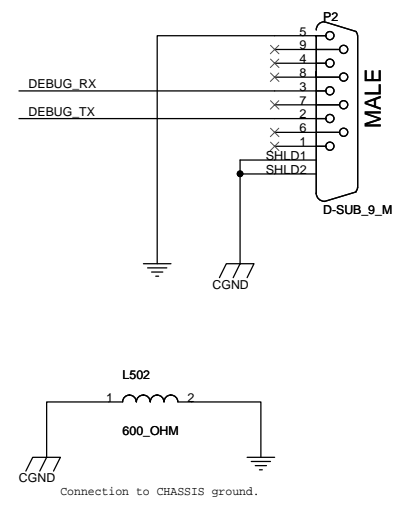
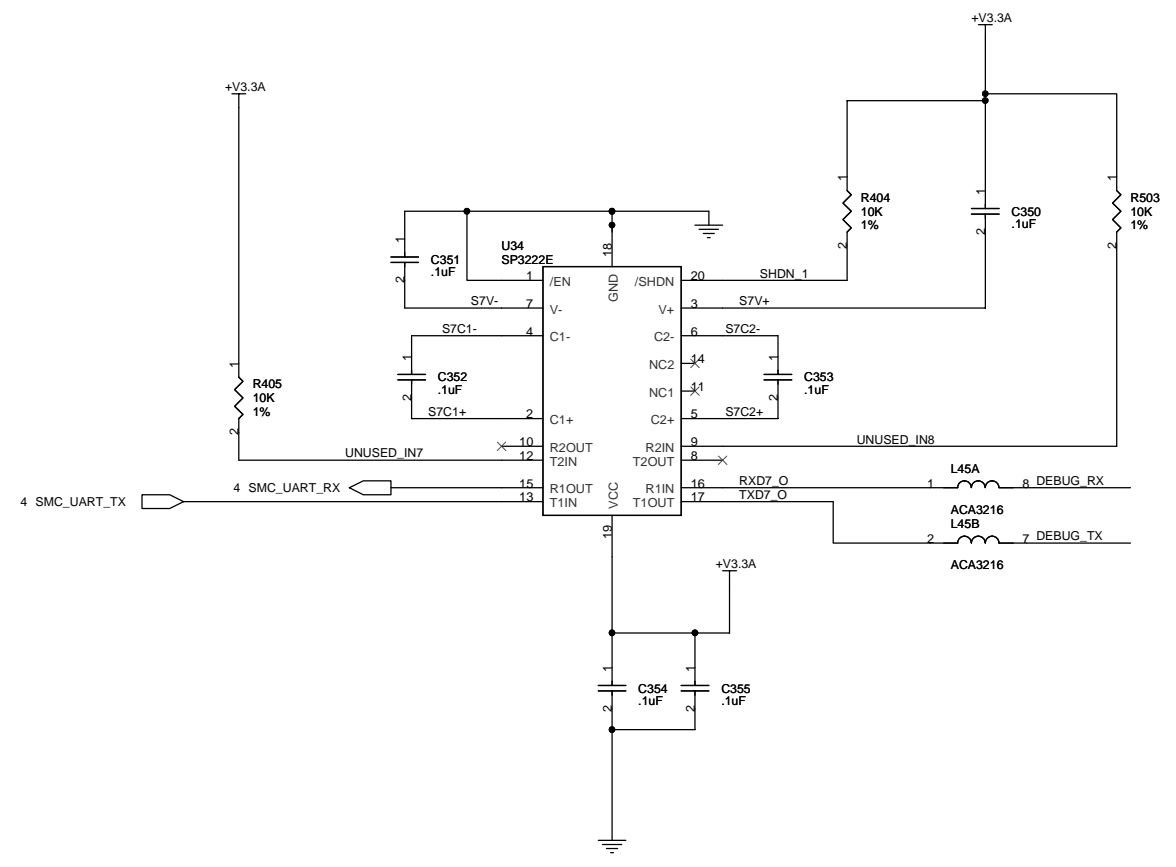

<Variant Name>

B	See updates 3-25-08 thru 4-9-08	04/09/08	CA
A	See updates 2-26-08	02/26/08	CA
Rev	Description / ECN	Date	Ini.
Title		APPLIED DATA SYSTEMS, INC. 10260 Old Columbia Rd, Suite G Columbia, MD 21046 1-800-541-2003	
Size	Document Number	640122-300R	Rev
Date:	Monday, April 14, 2008	Sheet	32 of 33

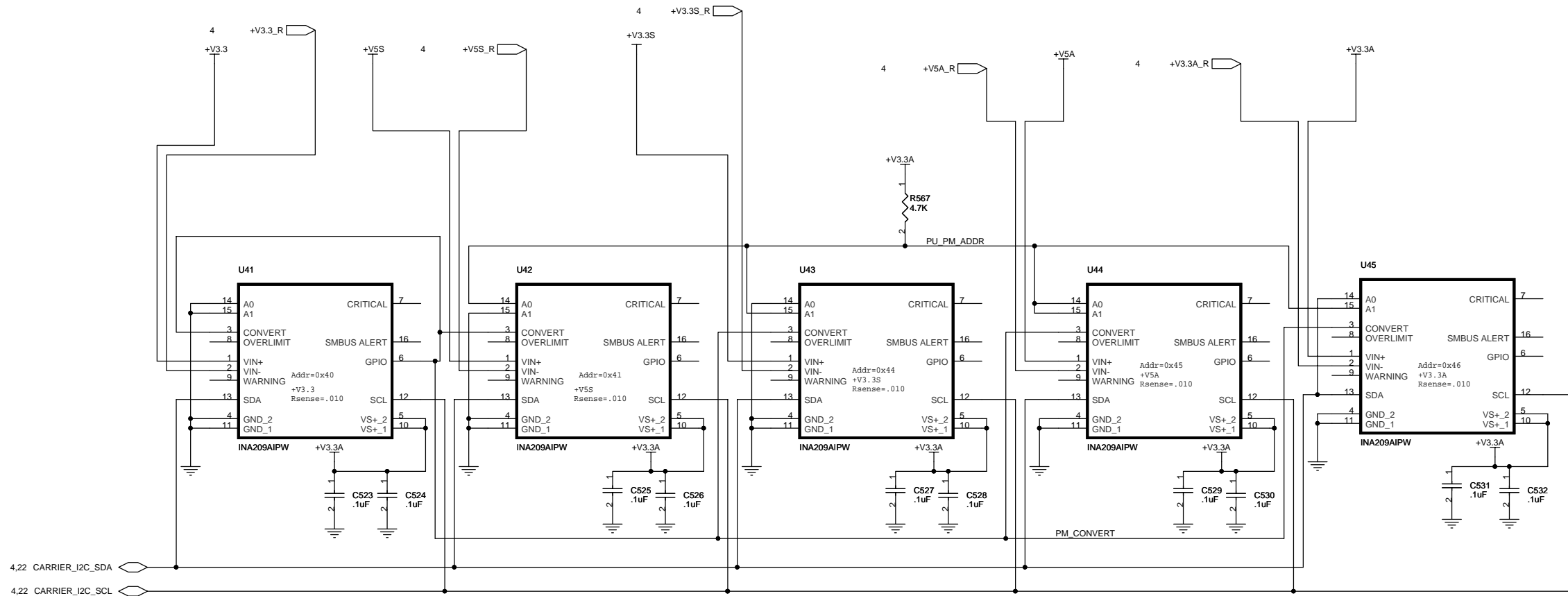

<Variant Name>

B	See updates 3-25-08 thru 4-9-08	04/09/08	CA
A	See updates 2-26-08	02/26/08	CA
Rev	Description / ECN	Date	Ini.
Title		APPLIED DATA SYSTEMS, INC. 10260 Old Columbia Rd, Suite G Columbia, MD 21046 1-800-541-2003	
Size	Document Number	640122-300R	Rev B
Date:	Monday, April 14, 2008	Sheet	33 of 33