

# **DynaCOR 10-00**

**Rugged compact computer featuring the Catalyst XL SBC**

## Trademarks

All trademarks both marked and unmarked appearing in this document are the property of their respective owners.

## Revision history

Revision	Description	Date
1.0	First release	1 June 2012

# Table of contents

Trademarks.....	2
Revision history .....	2
<b>Table of contents .....</b>	<b>3</b>
<b>Important user information .....</b>	<b>5</b>
Alerts that can be found throughout this manual.....	5
Safety notices and warnings.....	6
<i>Do not operate in an explosive atmosphere</i> .....	6
<i>Antistatic precautions</i> .....	6
<i>Connection to power supply or other devices</i> .....	6
<i>Installation</i> .....	7
<i>Ventilation</i> .....	7
<i>Maintenance</i> .....	7
<i>Cleaning</i> .....	7
Life support policy.....	8
Warranty .....	8
CE notice and R&TTE compliance .....	8
WEEE .....	9
RoHS .....	9
Technical assistance .....	10
<i>Transportation</i> .....	10
<i>Device labelling</i> .....	10
<b>Product overview .....</b>	<b>11</b>
<b>Product specifications.....</b>	<b>12</b>
Technical specifications.....	12
Front panel maintenance interfaces .....	13
<i>MA1 interface: 2x Maintenance USB ports and 1x Maintenance RS232 serial port</i> .....	14
<i>MA2 interface: 1x Maintenance VGA output</i> .....	14
Rear Panel Interfaces.....	15
<i>A1, A2, A3 and A4 connectors</i> .....	16
<i>M1 connector</i> .....	16
<i>M2 connector</i> .....	16
<i>M3 connector</i> .....	16
<b>Features Availability .....</b>	<b>17</b>
Localization features (GPS).....	17
Wi-Fi features .....	17
Communication features (HSUPA).....	18
Serial Ports .....	18
Optoisolated digital I/O features .....	18
<i>Optoisolated digital inputs (DIN1 to DIN10)</i> .....	18
<i>Optoisolated odometer input</i> .....	19
<i>Optoisolated digital outputs (DOUT1 to DOUT5)</i> .....	21
<b>System installation and use.....</b>	<b>22</b>
Unpacking.....	22
Usage .....	22
Installation notes.....	23
Mounting information .....	24

<i>Install the DynaCOR 10-00 using the four M4 square nuts</i> .....	24
<i>Install the DynaCOR 10-00 using the mounting brackets</i> .....	25
Warnings about electrical and power connections .....	26
How to supply the power .....	27
<b>I/O Devices</b> .....	<b>28</b>
<b>Physical characteristics</b> .....	<b>29</b>
Operating characteristics .....	29
<i>Electrical operating characteristics</i> .....	29
<i>Environmental specifications</i> .....	29
Mechanical characteristics .....	30
<i>DynaCOR 10-00 dimensions</i> .....	30
<i>Mounting bracket dimensions</i> .....	31
<b>Optional external cables</b> .....	<b>32</b>
Cables for the rear panel .....	32
<i>E14-12-12-00</i> .....	32
<i>E14-10-10-00</i> .....	33
<i>E14-21-10-00</i> .....	34
Cables for the front panel maintenance interfaces .....	35
<i>703312001SL</i> .....	35
<i>703310001SL</i> .....	36
<b>Notes</b> .....	<b>37</b>

# Important user information

**Carefully read and understand the instructions in this manual before using this device.**

Whenever you have any doubt regarding the operation of this device, consult this manual or contact your local Eurotech Technical Support Team (see the last page of this manual for details).



Keep this manual for future reference.

**To lower the risk of personal injury, electric shock, fire or damage to equipment, observe the following precautions, as well as using good technical judgment, whenever installing or using the device.**

Eurotech has made every effort to ensure the accuracy of this document; however, Eurotech assumes no liability resulting from any error/omission in this document, or from the use of the information contained herein.

Eurotech reserves the right to revise this document or to make changes to its content at any time without any obligation to notify any person of such revision or changes.

## Alerts that can be found throughout this manual

SYMBOL	MEANING
	<p><b>DANGER!</b> Information highlighting potential electrical shock hazards:</p> <ul style="list-style-type: none"> <li>• Personal injury or death could occur.</li> <li>• Damage to the system, connected peripheral devices, or software could occur.</li> </ul> <p>Always use appropriate safety precautions. Also ensure that the installation meets all the requirements as set out for the environment that the equipment will be deployed in.</p>
	<p><b>WARNING!</b> Information highlighting potential hazards:</p> <ul style="list-style-type: none"> <li>• Personal injury or death could occur.</li> <li>• Damage to the system, connected peripheral devices, or software could occur.</li> </ul> <p>Always use appropriate safety precautions. Also ensure that the installation meets all the requirements as set out for the environment that the equipment will be deployed in.</p>
	<p><b>NOTE</b> These will highlight important features or instructions.</p>

## Safety notices and warnings

Observe the following safety precautions during all phases of operation, service, and repair of the device. Failure to comply with these precautions or with specific warnings elsewhere in this manual violates safety standards of design, manufacture, and intended use of the device.

Eurotech assumes no liability for the customer's failure to comply with these requirements.

The safety precautions listed below represent warnings of certain dangers of which Eurotech is aware. You, as the user of the device, should follow these warnings and all other safety precautions necessary for the safe operation of the device in your operating environment.

### *Do not operate in an explosive atmosphere*

---



**WARNING!**

Do not operate the equipment in the presence of flammable gases or fumes. Operation of any electrical equipment in such an environment constitutes a definite safety hazard.

---

### *Antistatic precautions*

---



**WARNING!**

To avoid ESD (Electro Static Discharge) damage, always use appropriate antistatic precautions when handling any electronic equipment.

---

### *Connection to power supply or other devices*

---



**DANGER!**

Before applying power to the system, thoroughly review all installation, operation, and safety instructions.

Failure to install the system power supply correctly or to follow all operating instructions correctly may create an electrical shock hazard, which can result in personal injury or loss of life, and/or damage to equipment or other property

---

- To avoid injuries, always disconnect power and discharge circuits before touching them.
- Only start the device with a power supply that meets the requirements stated on the voltage label. In case of uncertainties about the required power supply, please contact the Eurotech Technical Support Team or the electricity authority
- Before connecting other equipment carefully read any supplied instructions
- Always disconnect the power before connecting or disconnecting cables
- Do not perform connections with wet hands
- Check any power cords for damage before use
- Use certified power cables. The power cable must meet the requirements (voltage and current) of the device.
- Position cables with care. Avoid positioning cables in places where they may be trampled on or compressed by objects placed on them. Take particular care of the plug, power-point and outlet of power cable
- Avoid overcharging any power outlets
- Only apply power to the device or connected equipment after checking that all the above conditions have been met

## Installation

---

**WARNING!**

- Verify that the mounting location can withstand the added loads caused by the addition of the device, it should be firmly secured so that it will not cause any potentially hazardous situations (e.g. falling down due to vibration or shock)
  - Do not operate the device near heat sources or flames.
- 

**NOTE:**

If the device must be moved from one place to another with different ambient temperatures, ensure sufficient time for the temperature of the device to stabilize before repowering.

---

## Ventilation

---

**WARNING!**

Ensure adequate ventilation to avoid overheating, Eurotech suggests the following steps:

- When installing the device within a cabinet, rack or other enclosed space, be sure to leave sufficient space to allow adequate air circulation
  - Do not block any ventilation openings
- 

## Maintenance

---

**DANGER!**

- Never open, dismantle or repair the device!
- For your maintenance or repair requirement please contact a qualified Eurotech engineer.

If the device does not function correctly and you are unable to find a solution, feel free to contact the Eurotech Technical Support Team.

---

If the equipment does not work properly, especially if it smells unusual, unplug it immediately and contact the Eurotech Technical Support Team (see last page of this manual for further details).

## Cleaning

---

**WARNING!**

When cleaning the device, remember to:

- Ensure sufficient ESD protection during the cleaning process
  - Remove any power from the device
  - When cleaning an enclosed system or peripheral use a dry cloth on the external casing
  - With single boards, use only a low power air brush or soft bristled paintbrush
  - Do not use detergents, aerosol sprays, solvents or abrasive sponges
-

## Life support policy



**WARNING!**

Do not use Eurotech products as critical components of life support devices or systems without the express written approval of Eurotech Spa.

## Warranty

Please contact your local Eurotech Sales Office for detailed warranty terms and conditions. See the last page of this manual for further details.

## CE notice and R&TTE compliance

This product is CE marked.

The CE mark on the product indicates that it conforms to the essential requirements of the applicable EC directives.

Eurotech is not responsible for the use of its products together with equipment (e.g. power supplies, personal computers, etc...) that are not CE marked and compliant with technical requirements specified in this manual.



This product also meets the essential requirements and other relevant provisions of Directive 1999/5/EC.

This product is designed to work in the following Member States and other countries using the R&TTE Directive: Austria, Belgium, Bulgaria, Cyprus, Czech Republic, Denmark, Estonia, Finland, France, Germany, Greece, Hungary, Iceland, Ireland, Italy, Latvia, Lithuania, Luxembourg, Malta, Netherlands, Norway, Poland, Portugal, Romania, Slovakia, Slovenia, Spain, Sweden, Switzerland, Turkey and the United Kingdom.



**Laws may change over time. Eurotech advises to check with local authorities for changes / updates.**



**WARNING!**

if you are not sure of your national regulations, please see:

- [http://ec.europa.eu/enterprise/sectors/rtte/index\\_en.htm](http://ec.europa.eu/enterprise/sectors/rtte/index_en.htm)
- <http://www.ero.dk/rtte>



## WEEE

The information below complies with the regulations set out in the 2002/96/EC directive, subsequently superseded by 2003/108/EC. It refers electrical and electronic equipment and the waste management of such products.

When disposing of a device, including all of its components, subassemblies and materials that are an integral part of the product, you should consider the WEEE directive.

The use of the following symbol, attached to the equipment, packaging, instruction literature, or the guarantee sheet, states that the device has been marketed after August 13th 2005, and implies that you must separate all of its components when possible, and dispose of them in accordance with local waste disposal legislations:



- Because of the substances present in the equipment, improper use or disposal of the refuse can cause damage to human health and the environment.
- With reference to WEEE, it is compulsory not to dispose of the equipment with normal urban refuse; an arrangement for separate collection and disposal is essential.
- To avoid any possible legal implications contact your local waste collection body for full recycling information.

## RoHS

This device, including all the components, subassemblies and the consumable materials that are an integral part of the product, have been manufactured in compliance with the European directive 2002/95/EC known as the RoHS directive (Restrictions of the use of certain Hazardous Substances). This directive targets the reduction of certain hazardous substances previously used in electrical and electronic equipment (EEE).

## Technical assistance

For any technical questions, or if you cannot isolate a problem with your device, or for any enquiry about repair and returns policies, feel free to contact your local Eurotech Technical Support Team (see the last page of this manual for details).

## Transportation

When transporting any module or system, for any reason, it should be packed using anti-static material and placed in a sturdy box with enough packing material to adequately cushion it.



**Warning:**  
Any product returned to Eurotech that is damaged due to inappropriate packaging will not be covered by the warranty!

## Device labelling

On the front side of the device you will find a label displaying the following information:

- A** Model Number
- B** Serial Number (example)
- C** Power Requirements

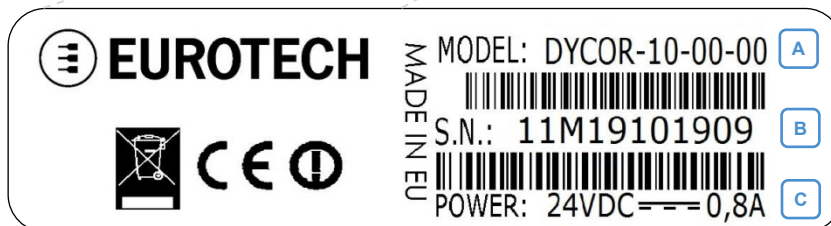
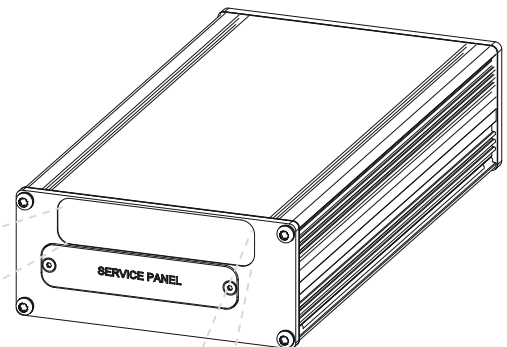

## Product overview

The DynaCOR 10-00 is a rugged mobile computer developed for installation on-board rail vehicles to perform localization and radio-communication operations.

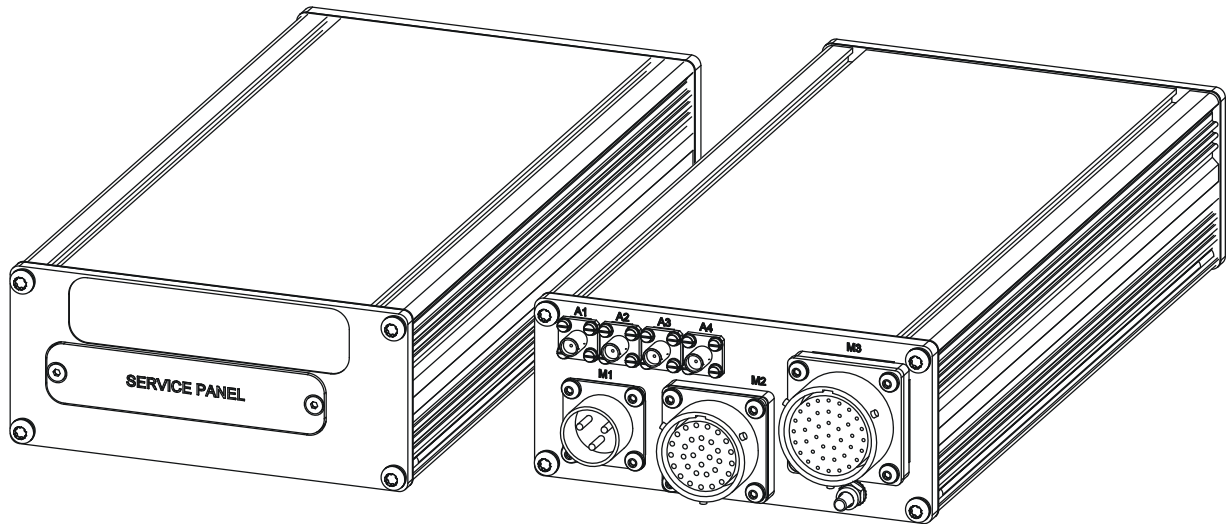

Figure 1. DynaCOR 10-00 front and rear view

# Product specifications

## Technical specifications

SPECIFICATIONS	DESCRIPTION
<b>Processor</b>	Eurotech Catalyst XL Intel Atom Z510P, 1.1GHz, 512MB RAM soldered on board
<b>Mass Storage</b>	<ul style="list-style-type: none"> <li>2 GB flash disk soldered on board</li> </ul>
<b>Wireless Characteristics</b>	<ul style="list-style-type: none"> <li>Localization:                             <ul style="list-style-type: none"> <li>50 channel GPS receiver; model UBlox LEA-5A</li> </ul> </li> <li>Communication:                             <ul style="list-style-type: none"> <li>Wi-Fi 802.11 a/b/g/n PCIe Half mini module; model Intel® Centrino® Advanced-N 6205</li> <li>HSUPA module; model Sierra Wireless MC8790 (data only)</li> </ul> </li> </ul>
<b>Communication Interfaces</b>	<ul style="list-style-type: none"> <li>Power IN +24VDC (+, - and earth chassis) + Key IN</li> <li>5x Optoisolated digital outputs</li> <li>10x Optoisolated digital inputs</li> <li>1x Optoisolated odometer digital input</li> <li>1x USB 2.0 port (available only for maintenance)</li> <li>Audio ports:                             <ul style="list-style-type: none"> <li>1x Stereo microphone input</li> <li>1x Stereo headphone output</li> <li>1x Stereo speakers output</li> </ul> </li> <li>2x Gigabit Ethernet ports, no LED indicators</li> <li>1x Optoisolated RS232 serial port</li> <li>1x Optoisolated RS485 serial port, software configurable as RS422/RS232</li> <li>1x CAN port</li> </ul>
<b>Maintenance Interfaces (accessible removing the Service Panel)</b>	<ul style="list-style-type: none"> <li>1x Maintenance RS232 serial port</li> <li>2x Maintenance USB ports:                             <ul style="list-style-type: none"> <li>1x USB for keyboard</li> <li>1x USB for mouse.</li> </ul>                             Keyboard and mouse can also be connected to the Maintenance USB 2.0 port using an USB HUB                         </li> <li>1x Maintenance VGA output</li> <li>1x Reset pushbutton</li> <li>1x µSD card slot (µSD card not included)</li> <li>1x SIM card slot (SIM card not included)</li> <li>4x Green LED indicators</li> </ul>
<b>Power Supply</b>	24 V DC nominal (9 V DC minimum; 36 V DC maximum)
<b>Battery</b>	A Super-Cap to maintain the RTC for 4 hours at 25°C (typical)
<b>Cooling</b>	Fanless cooling system with no moving parts
<b>Temperature</b>	<ul style="list-style-type: none"> <li>Operating: Class T1 ref. EN50155 [-25°C to +55°C (70°C for 10 minutes)]</li> <li>Storage : -30°C to +80°C</li> </ul>
<b>Relative Humidity</b>	<95% at 45°C non-condensing
<b>Weight</b>	3 kg (max)
<b>Dimensions (L x W x H; mm)</b>	254 x 129 x 57
<b>Chassis Description</b>	Black ultra-light extruded aluminium alloy enclosure
<b>IP Rating</b>	IP65
<b>Operating System Support</b>	Wind River Linux
<b>ESF Ready</b>	Yes
<b>EDC Ready</b>	Yes
<b>Compliance</b>	<ul style="list-style-type: none"> <li>CE</li> <li>EN 50155 (Railway applications)</li> <li>EN 61373 (Vibrations &amp; Shocks)</li> <li>EN 60950 (Safety)</li> <li>EN 61000 (Burst Immunity test)</li> <li>EN 60068 (Temperature test)</li> </ul> Designed to meet: <ul style="list-style-type: none"> <li>DIN-5510-2 (German Fire and Smoke) and ISO-11170 (Italian Fire and Smoke)</li> <li>Load Dump (for 24V In): ISO 7637-2 (2004-06)</li> </ul>
<b>Peripherals and accessories</b>	Cable kit with standard connectors

## Front panel maintenance interfaces

The maintenance interfaces are available on the front panel after removing the Service Panel. To remove the Service Panel unscrew the two T10Torx screws.



**WARNING!**  
The IP protection of the system will be degraded by the removal of the Service Panel

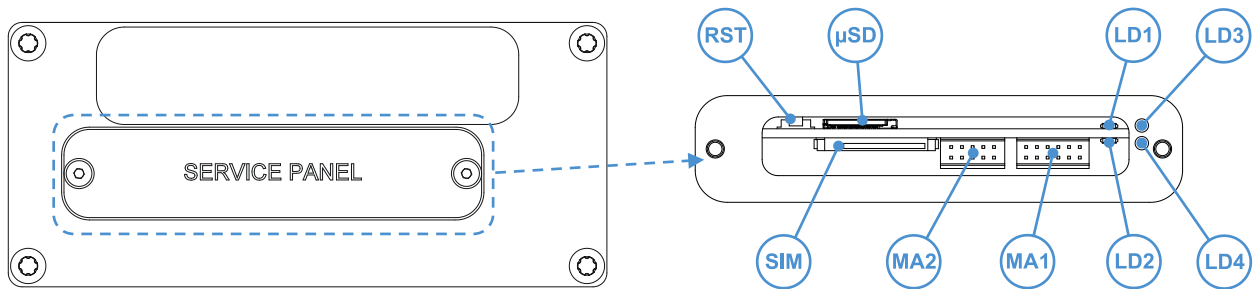
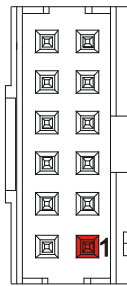

Figure 1. DynaCOR 10-00: maintenance interfaces

INTERFACE	SPECIFICATIONS	FUNCTION / NOTES
LD1, 2, 3 and 4	Green LED indicators	<p>LD1: Blinks when there is IDE activity</p> <p>LD2: Reserved</p> <p>LD3: Power good</p> <p>LD4: Power ON</p> <p><b>NOTE:</b> The LED indicators aren't programmable</p>
MA1	<p><b>Connector:</b></p> <ul style="list-style-type: none"> <li>Type: Male Minitex; 6x2 pin, pitch 2mm</li> <li>Manufacturer: FCI or equivalent</li> <li>P/N: 98464-G61-12ULF</li> </ul> <p><b>Recommended counterpart:</b></p> <ul style="list-style-type: none"> <li>Type: Female</li> <li>Manufacturer: FCI or equivalent</li> <li>Housing P/N: 90311-012LF</li> <li>Contacts P/N: 77138-101-LF</li> </ul>	<ul style="list-style-type: none"> <li>2x Maintenance USB ports</li> <li>1x Maintenance RS232 serial port</li> </ul>
MA2	<p><b>Connector:</b></p> <ul style="list-style-type: none"> <li>Type: Male Minitex; 5x2 pin, pitch 2mm</li> <li>Manufacturer: FCI or equivalent</li> <li>P/N: 98464-G61-10ULF</li> </ul> <p><b>Recommended counterpart:</b></p> <ul style="list-style-type: none"> <li>Type: Female</li> <li>Manufacturer: FCI or equivalent</li> <li>Housing P/N: 90311-010LF</li> <li>Contacts P/N: 77138-101-LF</li> </ul>	<ul style="list-style-type: none"> <li>1x Maintenance VGA output</li> </ul>
SIM	Push-push SIM card holder	The SIM card is not included. The SIM card can be only inserted with the contacts facing the μSD card holder (the notch on the SIM card will avoid incorrect insertion).
μSD	Push-push μSD card holder	The μSD card is not included. The μSD card can be only inserted with the contacts facing the SIM card holder.
RST	Reset push-button	If pressed a system hardware reset will be executed

Table 1. Description of the maintenance interfaces

**MA1 interface: 2x Maintenance USB ports and 1x Maintenance RS232 serial port**



PIN#	SIGNAL		PIN#	SIGNAL	
1	Maintenance	+5V	2	Maintenance	+5V
3	USB2	Data +	4	USB1	Data +
5		Data -	6		Data -
7		GND	8		GND
9	Maintenance Serial Port	TX	10	Maintenance Serial Port	RX
11	GND	GND	12	Reserved	Reserved

**MA2 interface: 1x Maintenance VGA output**

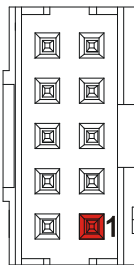

PIN#	SIGNAL	PIN#	SIGNAL
1	BLUE	2	GREEN
3	RED	4	N.C.
5	GND	6	GND
7	HSYNC	8	SCL
9	VSYNC	10	SDA

## Rear Panel Interfaces

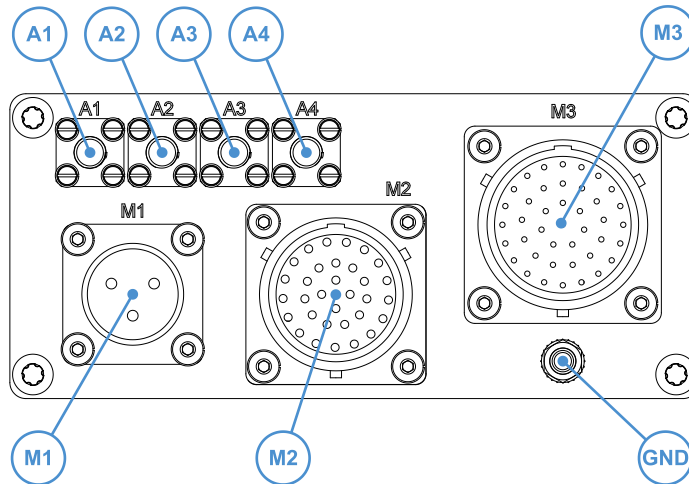
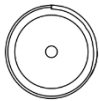

Figure 2. DynaCOR 10-00: rear panel layout

INTERFACE	CONNECTOR TYPE	FUNCTION / NOTES
A1, A2, A3, A4	<p><b>Connector</b> Female panel mount SMA</p> <p><b>Recommended counterpart</b> Male SMA connector</p>	<ul style="list-style-type: none"> <li>A1: GPS antenna</li> <li>A2: Wi-Fi primary antenna</li> <li>A3: Wi-Fi secondary antenna</li> <li>A4: HSUPA antenna</li> </ul>
M1	<p><b>Connector</b> Male box-mounting MIL 26482 series:</p> <ul style="list-style-type: none"> <li>Type: Size 12; 3-pin</li> <li>PART #: Souriau 851-02E12-03P5044</li> </ul> <p><b>Recommended counterpart</b> Female MIL 26482 series:</p> <ul style="list-style-type: none"> <li>Type: Size 12; 3-pin</li> <li>PART #: Souriau 851-06RC12-03S5044</li> </ul>	<ul style="list-style-type: none"> <li>Power Input (VIN)</li> <li>Key Input (Key IN)</li> </ul>
M2	<p><b>Connector</b> Female box-mounting MIL 26482 series:</p> <ul style="list-style-type: none"> <li>Type: size 18; 32-pin</li> <li>PART #: Souriau 851-02E18-32S5144</li> </ul> <p><b>Recommended counterpart</b> Male MIL 26482 series:</p> <ul style="list-style-type: none"> <li>Type: size 18; 32-pin</li> <li>PART #: Souriau 851-06RC18-32P5044</li> </ul>	<ul style="list-style-type: none"> <li>5x Optoisolated digital outputs (DOUT1 to DOUT5)</li> <li>10x Optoisolated digital inputs (DIN1 to DIN10)</li> <li>1x Optoisolated odometer digital input (ODOM+/-)</li> <li>1x Maintenance USB 2.0 port (USB)</li> <li>Audio ports:                             <ul style="list-style-type: none"> <li>1x Stereo microphone input</li> <li>1x Stereo headphone output</li> <li>1x Stereo speakers output</li> </ul> </li> </ul>
M3	<p><b>Connector</b> Female box-mounting MIL 26482 series:</p> <ul style="list-style-type: none"> <li>Type: size 20; 41-pin</li> <li>PART #: Souriau 851-02E20-41S5144</li> </ul> <p><b>Recommended counterpart</b> Male MIL 26482 series:</p> <ul style="list-style-type: none"> <li>Type: size 20; 41-pin</li> <li>PART #: Souriau 851-06RC20-41P5044</li> </ul>	<ul style="list-style-type: none"> <li>2x Gigabit Ethernet ports, no LED indicators (ETH1 and ETH2); (optionally configurable as 10/100Mbps)</li> <li>1x Optoisolated RS232 serial port (SER1)</li> <li>1x Optoisolated RS485 serial port (SER2); software configurable as RS422/RS232</li> <li>1x CAN port</li> </ul>
Ground	M4 screw; length 12 mm	<ul style="list-style-type: none"> <li>System ground connection</li> </ul>

Table 2. Description of rear panel interfaces

### A1, A2, A3 and A4 connectors



CONN#	SIGNAL
A1	GPS antenna
A2	Wi-Fi Primary antenna
A3	Wi-Fi Secondary antenna
A4	HSUPA antenna

### M1 connector

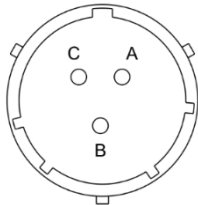

PIN#	SIGNAL
A	VIN+
B	Key IN
C	VIN-

### M2 connector

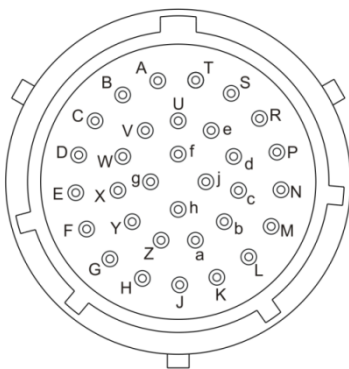

PIN#	SIGNAL	PIN#	SIGNAL		
A	Digital In	DIN1	T	Digital Out	DOUT5
B		DIN2	U	Microphone In	MIC_IN_L
C		DIN3	V		MIC_IN_R
D		DIN4	W	Headphone Out	HP_OUTL
E		DIN5	X		HP_OUTR
F		DIN6	Y	Speakers Out Right	ROUT+
G		DIN7	Z		ROUT-
H		DIN8	a	Speakers Out Left	LOUT+
J		DIN9	b		LOUT-
K		DIN10	c	Odometer	ODOM+
L	DIN_GND	d		ODOM-	
M	Digital Out	DOUT_GND	e		GND
N		DOUT1	f	USB	USB_+5
P		DOUT2	g		USB_D+
R		DOUT3	h		USB_D-
S		DOUT4	j		USB_GND

### M3 connector

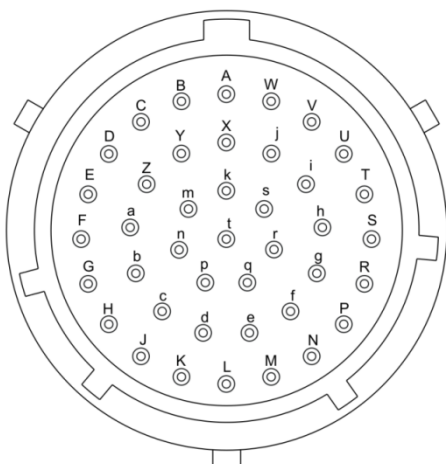

PIN#	SIGNAL	PIN#	SIGNAL				
A	ETH1	ETH1 RX2+	Y	SER1	RTS1		
B		ETH1 RX2-	Z		CTS1		
C		ETH1 TX2+	a		RI1		
D		ETH1 TX2-	b		DTR1		
E		ETH1 RX1+	c		TXD1		
F		ETH1 RX1-	d		RXD1		
G		ETH1 TX1+	e		DCD1		
H		ETH1 TX1-	f		GND ISO	GND ISO	
J		ETH2	ETH2 RX2+		g	SER2	DSR2
K			ETH2 RX2-		h		RTS2
L	ETH2 TX2+		i	CTS2			
M	ETH2 TX2-		j	RI2			
N	ETH2 RX1+		k	DTR2			
P	ETH2 RX1-		m	TXD2			
R	ETH2 TX1+		n	RXD2			
S	ETH2 TX1-		p	DCD2			
T	Reserved	Reserved	q	GND ISO	GND ISO		
U		Reserved	r	CAN	CAN_P		
V		Reserved	s		CAN_N		
W		Reserved	t		GND_CAN		
X	SER1	DSR1					



# Features Availability

## Localization features (GPS)

The DynaCOR 10-00 includes the 50-channel UBlox LEA-5A GPS receiver. The following table lists the main receiver's features:

PARAMETER	SPECIFICATION	
<b>Receiver type</b>	50 Channels GPS L1 frequency, C/A Code GALILEO Open Service L1 frequency	
<b>Time-To-First-Fix<sup>1</sup></b>	Cold Start (Autonomous)	32s
	Warm Start (Autonomous)	32s
	Hot Start (Autonomous)	<1s
	Aided Starts <sup>2</sup>	<3s
<b>Sensitivity<sup>3</sup></b>	Tracking & Navigation	-160 dBm
	Reacquisition	-160 dBm
	Cold Start (Autonomous)	-143 dBm
<b>Horizontal position accuracy<sup>4</sup></b>	Autonomous	< 2.5 m
	SBAS	< 2.0 m
<b>Accuracy of Time Pulse signal</b>	RMS	30 ns
	99%	< 60 ns
	Time Pulse	Configurable f = 0.25 to 999 Hz (Tp = 1/f - 1ms)
<b>Max navigation update rate</b>	< 4 Hz (ROM) / 2 Hz FLASH	
<b>Velocity accuracy<sup>6</sup></b>	0.1m/s	
<b>Heading accuracy<sup>7</sup></b>	0.5 degrees	
<b>Dynamics</b>	≤ 4 g	
<b>Operational limits<sup>8</sup></b>	Altitude	50000 m
	Velocity	500 m/s

<sup>1</sup> All satellites at -130 dBm

<sup>2</sup> Dependent on aiding data connection speed and latency

<sup>3</sup> Demonstrated with a good active antenna

<sup>4</sup> CEP, 50%, 24 hours static, -130dBm, SEP: <3.5m

<sup>5</sup> Quantization error information can be used to compensate the granularity related error of the time pulse signal.

<sup>6</sup> 50% @ 30 m/s

<sup>7</sup> 50% @ 30 m/s

<sup>8</sup> Assuming Airborne <4g platform

A1 connector allows for the antenna connection.

## Wi-Fi features

The DynaCOR 10-00 includes the Intel® Centrino® Advanced-N 6205 Wi-Fi 802.11 a/b/g/n PCIe Half mini module.

The following table lists the main module's features:

FEATURE	DESCRIPTION
<b>IEEE WLAN Standard</b>	IEEE 802.11a/b/g/n, 802.11d, 802.11e, 802.11i, 802.11h
<b>Architecture</b>	Infrastructure or ad hoc (peer-to-peer)
<b>Roaming<sup>1</sup></b>	Supports seamless roaming between respective access points (802.11b, 802.11g, 802.11a/b/g, and 802.11a/b/g/n)
<b>Authentication<sup>2</sup></b>	WPA and WPA2, 802.1X (EAP-TLS, TTLS, PEAP, LEAP, EAP-FAST), EAP-SIM, EAP-AKA
<b>Authentication Protocols<sup>2</sup></b>	PAP, CHAP, TLS, GTC, MS-CHAP*, MS-CHAPv2
<b>Encryption<sup>2</sup></b>	64-bit and 128-bit WEP, AES-CCMP, TKIP
<b>Product Safety<sup>2</sup></b>	UL, C-UL, CB (IEC 60950-1)

<sup>1</sup> Roaming is supported only between each respective band and mode of access points

<sup>2</sup> Security solutions support level depends on the underlying operating system software

A2 and A3 connectors allow for the antenna connection.

## Communication features (HSUPA)

The DynaCOR 10-00 includes the Sierra Wireless MC8790 (data only) module. The following table lists the main features:

FEATURE	DESCRIPTION
<b>Air interface</b>	HSUPA, HSDPA, EDGE, GPRS, GSM
<b>Frequency Bands</b>	WCDMA 850/1900/2100 MHz EDGE/GPRS/GSM 850/900/1800/1900 MHz
<b>Approvals</b>	FCC, IC, CE, GCF, PTCRB, A-Tick, AT&T, Telstra, NTT DoCoMo, Softbank, Bell
<b>Downlink/uplink speeds</b>	Peak downlink speeds up to 7.2 Mbps and peak uplink speeds up to 5.76 Mbps

A4 connector allows for the antenna connection.

## Serial Ports

Two serial ports are available on the M3 connector:

- 1x RS232 serial port (SER1)
- 1x software configurable RS232/422/485 serial port (SER2)

## Optoisolated digital I/O features

The optoisolated digital I/Os available are:

- 10 inputs (DIN1 to DIN10)
- 1 odometer input (ODOM+ and ODOM-)
- 5 outputs (DOUT1 to DOUT5)

### Optoisolated digital inputs (DIN1 to DIN10)

The system has 10 optically isolated digital inputs (DIN1 to DIN10). Each input corresponds to a phototransistor optically coupled to the earth reference DIN\_GND, common to all digital inputs.

The response time of each input is 5 ms, thanks to an RC filter and a Schmitt trigger port, so the faster switching are filtered.

#### Electrical specifications:

CHARACTERISTIC	VALUE
<b>Logical zero threshold level</b>	< 1.5 V
<b>Logical one threshold level</b>	> 10.0 V
<b>Minimum pulse duration</b>	10 ms
<b>Response time</b>	5 ms
<b>Absorbed Current</b>	2.4 mA

#### Electrical schematic:

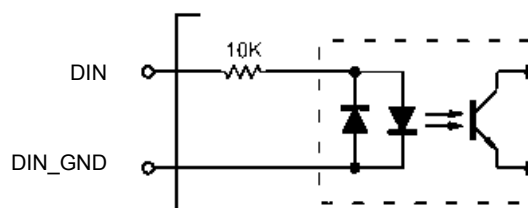

### Optoisolated odometer input

The odometer input is a digital interface used to count the input pulses, and determine with these the speed of the vehicle. The input, available on pins ODOM+ and ODOM- of the M1 connector, is an optically isolated input with programmable threshold level.

**Electrical specifications:**

CHARACTERISTIC	VALUE
Voltage Range	Minimum: 0 V Maximum: 32 V
Maximum Input Frequency	10 kHz

**Electrical schematic:**

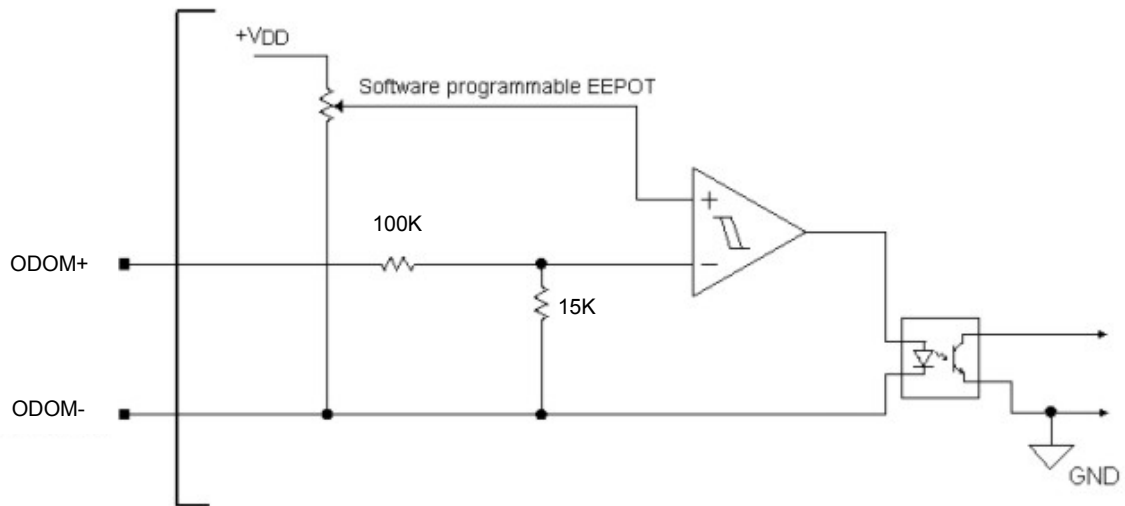

The purpose of the programmable input threshold is to allow you to configure the best threshold for an accurate and reliable reading; the input can be seen as a trigger that counts the input pulses and deletes any spurious. The ODOM+ input is applied to a comparator whose threshold is programmable via a digital potentiometer.

**Select the programmable threshold:**

The purpose of the programmable threshold is to allow the system integrator to choose the best threshold value for his applications.

First, the input signal is applied to a resistor divider, with about 100 kOhm input impedance.

Then the signal is compared with a programmable reference voltage threshold:

- If the input signal is higher than the programmed high threshold, the logic input is '1'
- If the input signal is lower than the programmed low threshold, the logic input is '0'



**NOTE:**

The programmable reference voltage comes from a 32-steps digital potentiometer (EEPOT: Electrically-Erasable Potentiometer), which wiper position is pre-set to mid-scale at every power-up.

The following table shows the available wiper settings with the corresponding threshold values (these values are measured with a 10 kHz square wave input signal having a duty cycle of 20% ~ 80%)

WIPER SETTING	LOW THRESHOLD [V]	HIGH THRESHOLD [V]
1	0.3	1.2
2	1.5	4.0
3	2.6	6.6
4	3.6	8.6
5	4.4	10.5
6	5.2	12.5
7	6.0	13.7
8	6.8	15.4
9	7.5	16.7
10	8.2	17.5
11	9.0	18.5
12	9.6	20.1
13	10.3	21.2
14	10.6	21.4
15	11.8	22.4
16	12.5	23.2
17	13.4	24.2
18	14.0	25.0
19	14.9	25.6
20	15.0	26.3
21	16.8	27.3
22	17.7	27.9
23	18.8	28.8
24	20.1	29.6
25	21.3	31.2
26	22.6	32.2
27	24.2	33.7
28	26.1	35.0
29	27.8	35.7
30	29.9	35.7
31	32.4	35.7
32	33.5	35.7

### Optoisolated digital outputs (DOUT1 to DOUT5)

Five optoisolated digital outputs (DOUT1 to DOUT5) are available. Outputs have a common ground connection: DOUT\_GND.



**NOTE:**

The isolation between the digital outputs and the rest of the system is 500VAC for 1 minute.

**Electrical specifications (with a pull-up resistor of 1kOhm to VIN = 30V):**

CHARACTERISTIC	VALUE
Maximum drain source voltage	36.0V
Maximum low logic level	0.4 V @ Id = 200 mA
Maximum current limit:	300mA

**Electrical schematic:**

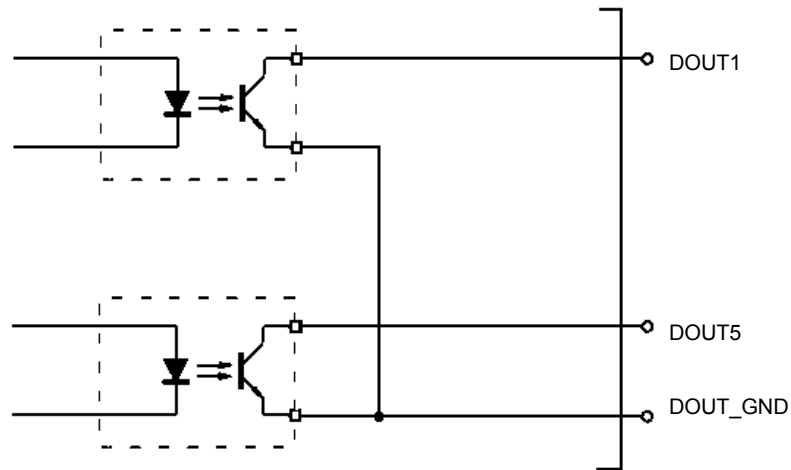

# System installation and use

Carefully read and understand the instructions of the chapter “**Important user information**” on page 5 before using the device.

To lower the risk of personal injury, electric shock, fire or damage to equipment, observe the following precautions, as well as using good technical judgment, whenever installing or using the device.



**WARNING!**

The installation of the product described in this manual can be only performed by qualified personnel and must be carried out in accordance with the standards.



**WARNING!**

To avoid ESD (Electro Static Discharge) damage, always use appropriate antistatic precautions (i.e.: use an antistatic wrist strap connected to ground) when handling any electronic equipment.

## Unpacking

When unpacking the equipment, ensure to remove all packaging material. All ventilation openings in the chassis must be free of obstructions. Thoroughly inspect the equipment for damage that may have occurred during shipment. If such damage has occurred, further inspection of the packaging material may be necessary.

Immediately contact your local Eurotech Sales Office (see the last page of this manual for further details) to register a claim.

## Usage

The product described in this manual (the unit) is a rugged mobile computer developed to be installed on-board rail vehicles to perform localization and radio-communication operations.

The unit is **NOT** intended for the following functions:

Function	Examples
<b>Vehicle direction controls</b>	Gears, Brakes, Suspension, Active steering, Speed limitation devices Engine management
<b>Driver positioning</b>	Seat or Steering wheel positioning
<b>Driver visibility</b>	Headlight controls, Windscreen wipers
<b>Functions related to the drivers, passengers and other road-users protection</b>	Airbag and Safety restraint systems
<b>Functions that could cause confusion to the driver or other road users</b>	<b>Optical disturbances:</b> Indicator control, Brake lights, Reversing lights, Light bars for emergency system, Warning indicators, Lamps or Displays related to functions in clauses (a) or (b) that may be observed in the direct view of the driver  <b>Acoustic disturbances:</b> Anti-theft alarm, Horns
<b>Functions related to vehicle data bus functionality</b>	Data transmission on vehicle data bus-systems, which are used to transmit data, required to ensure the correct functioning of other immunity-related functions
<b>Functions that affect vehicle statutory data</b>	Tachograph, Odometer

## Installation notes

**NOTE:**

The device can operate in vertical, transversal and longitudinal orientations.

**WARNING!**

Verify that the addition of the system does not cause instability or damage to the mounting location. Firmly secure the system.

Be aware of potentially hazardous situation when mounting the system (e.g. falling down). If required, use stiffeners to reinforce the mounting area.

**NOTE:**

When the unit is mounted, ensure adequate clearance distance for cabling and air circulation: there must be sufficient space to connect the cables and for the maintenance operations.

**WARNING!**

Make sure the temperature and humidity will stay within the ranges specified in the “[Environmental specifications](#)” paragraph on page 29.

Be aware of other devices that may raise the ambient temperature in the installation area, also the radiated heat of the system itself.

## Mounting information

There are two ways of installing the DynaCOR 10-00:

- Using the four M4 square nuts located in the two guide rails on the underside of the system. The four square nuts allow you to install the product in place using four M4 screws
- Using the two mounting brackets

### *Install the DynaCOR 10-00 using the four M4 square nuts*

Four M4 square nuts are located in two guide rails on the underside of the system.

**The maximum screw insertion depth should be 6 mm.**

To stop the screws from becoming loose we suggest using a thread locker and/or spring washers

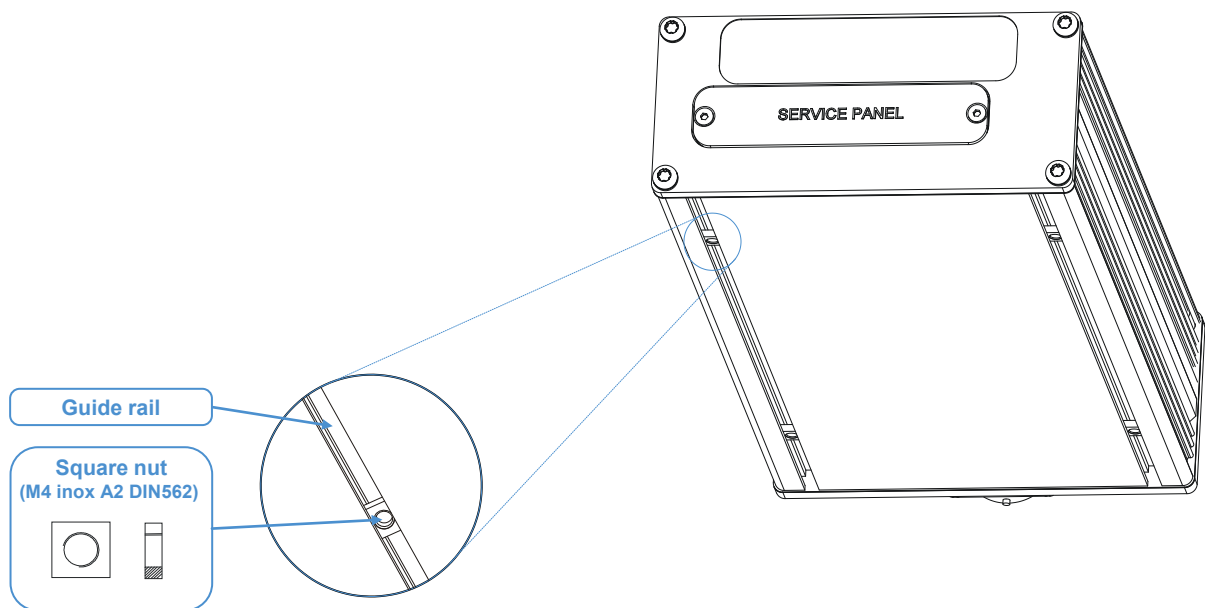

**NOTE:**

The maximum screw insertion depth is 6 mm.

To stop the screws from becoming loose we suggest using a thread locker and/or spring washers.



## Install the DynaCOR 10-00 using the mounting brackets

Follow these steps to install the DynaCOR 10-00 using the brackets:

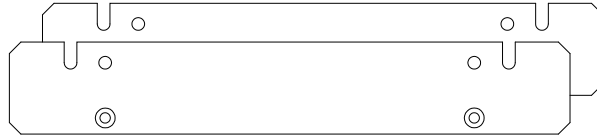

1. Secure the brackets to the square nuts using the four M4 screws provided

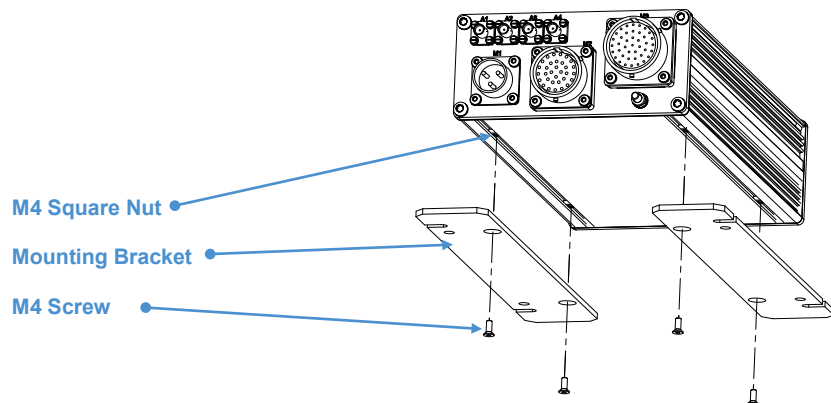

2. Now the DynaCOR 10-00 is ready to be installed in place.  
You will need to add all the necessary locking parts

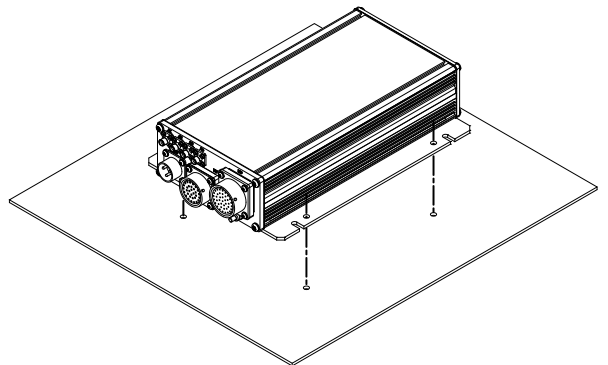

## Warnings about electrical and power connections



**DANGER!**

- Before supplying power to the product, verify the correct installation, the order of operations to follow and safety instructions
- Power have only to be connected after the installation of the system has been completed
- Do not connect or disconnect the cables with the system or the external apparatus switched on

**FAILURE TO INSTALL THE SYSTEM POWER SUPPLY CORRECTLY OR TO FOLLOW ALL OPERATING INSTRUCTIONS CORRECTLY MAY CREATE AN ELECTRICAL SHOCK HAZARD WHICH CAN RESULT IN PERSONAL INJURY OR LOSS OF LIFE, AND/OR DAMAGE TO EQUIPMENT OR OTHER PROPERTY.**



**WARNING!**

It is the responsibility of the system integrator to ensure that all connections are compliant with relevant standards for each type of interface.



**WARNING!**

The degree protection on the system is only obtained by covering the connectors properly. Be careful to use cables that ensure the seal of the connector. Unused connectors have to be covered with an appropriate plug. An improper cover of the connectors may result in damage to the system and other system's components due to a leaking seal.



**WARNING!**

See the paragraph "[Operating characteristics](#)" on page 29 for the power requirements of the product.

Use only cables that are appropriate to the power rating of the system.  
Make sure that during installation the system maintains a proper grounding.

# How to supply the power



**WARNING!**

- See “**Important user information**” on page 5 and “**Warnings about electrical and power connections**” on page 26 before powering the device.
- See the paragraph “**Operating characteristics**” on page 29 for the power requirements of the product.
- Use only cables that are appropriate to the power rating of the system.
- Make sure that during installation the system maintains a proper grounding.



**NOTE:**

When powering the system, the input voltage should be measured as close as possible to the power supply connector. This is to compensate for any cable losses, caused by cable length and other cable characteristics.

1. Set up a DC power source that meets the DynaCOR 10-00 power requirements:

CHARACTERISTIC	MINIMUM	NOMINAL	MAXIMUM
Input voltage range	9 V DC	24 V DC	36 V DC
Input current		0.8 A	
Inrush current		About 12 A	About 15 A

2. Make sure the DC power source is turned OFF
3. Realize the system power supply circuitry according to the diagram below:

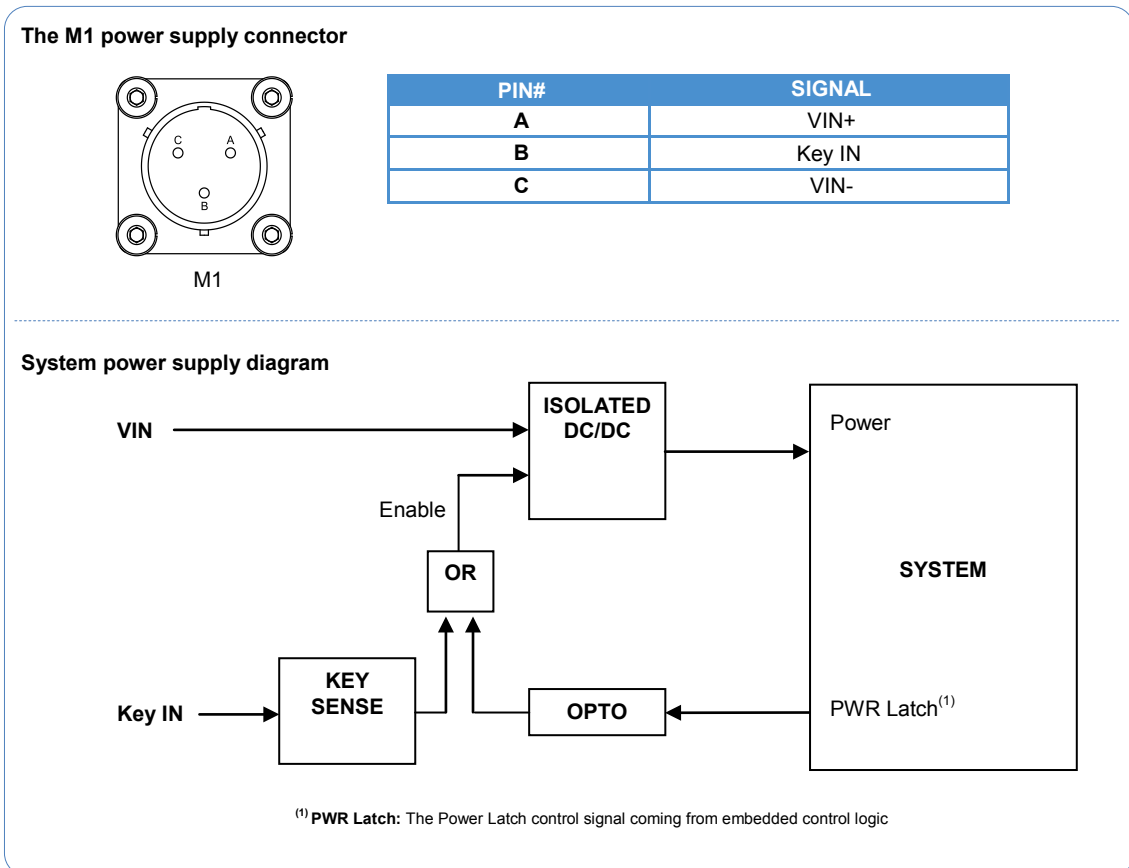

## I/O Devices

---

The “I/O devices” offer the following functions:

- Digital inputs
- Digital outputs
- Odometer
- Temperature monitor
- Power monitor
- Key input management
- CAN controller management

The functions are managed by an on-board microcontroller which communicates with the main CPU on a serial interface.

The following paragraphs will give you further details on the communication protocol.

# Physical characteristics

## Operating characteristics

### Electrical operating characteristics

CHARACTERISTIC	MINIMUM	NOMINAL	MAXIMUM
Input voltage range	9 V DC	24 V DC	36 V DC
Input current		0.8 A	
Inrush current		About 12 A	About 15 A



**NOTE:**  
The internal DC/DC converter is isolated.

### Environmental specifications

CHARACTERISTIC	DESCRIPTION
Operating Temperature	EN50155 Class T1 [-25 / +55 °C (70°C for 10 minutes)]
Storage Temperature	Min: -30 °C Max: +80 °C
Relative humidity	95% a 45°C non condensing

# Mechanical characteristics

## DynaCOR 10-00 dimensions

All dimensions are in millimetres.

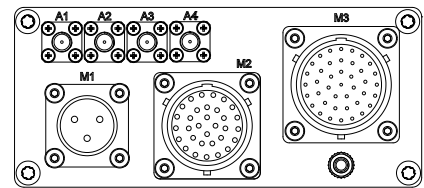
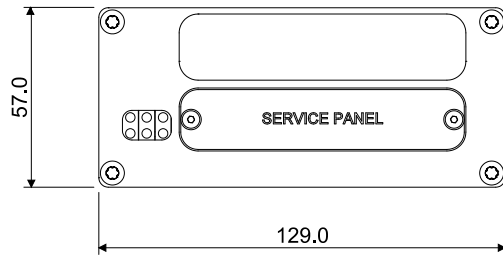
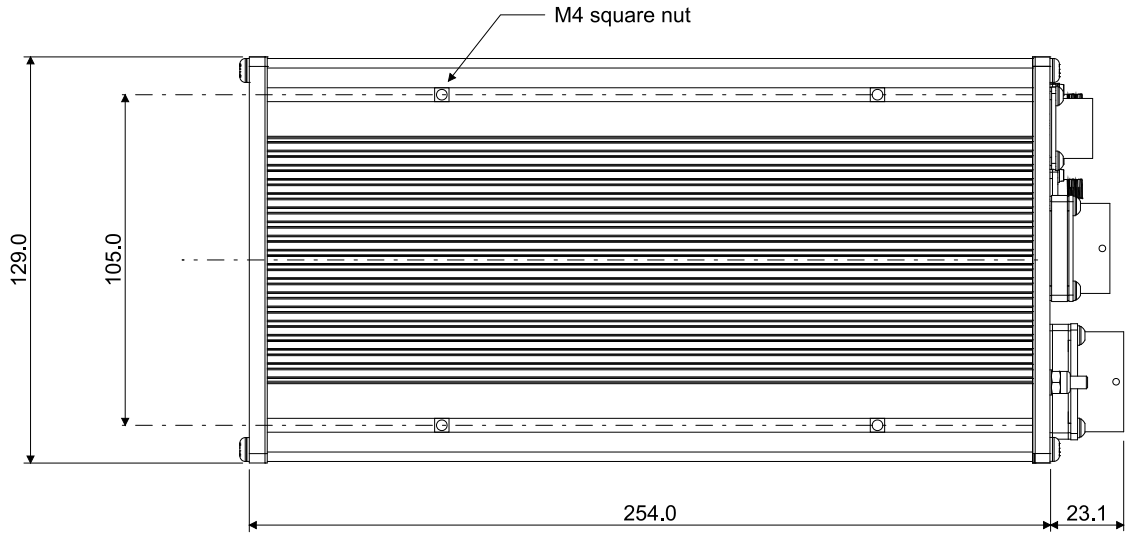

### Mounting bracket dimensions

All dimensions are in millimetres.

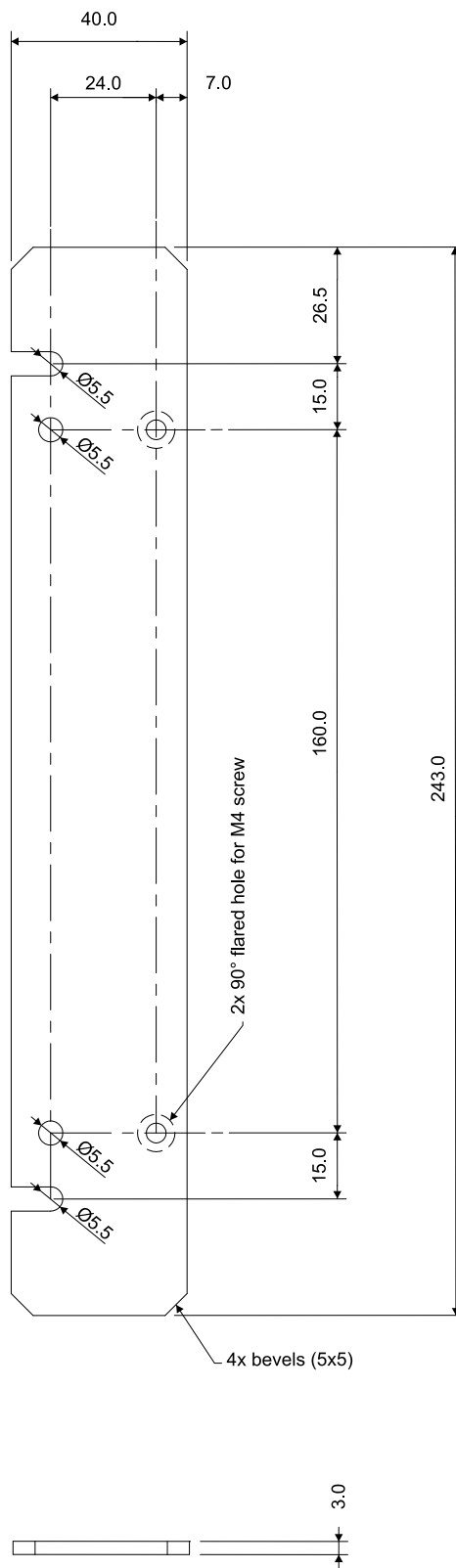

# Optional external cables

## Cables for the rear panel

The following external cables are available as option:

- **E14-12-12-00:** Cable for connecting Power supply and Key IN – to M1 connector
- **E14-10-10-00:** Cable for connecting Digital I/O, Odometer, USB, and Audio – to M2 connector
- **E14-21-10-00:** Cable for connecting Ethernet, SER1, SER2, and CAN – to M3 connector

### E14-12-12-00

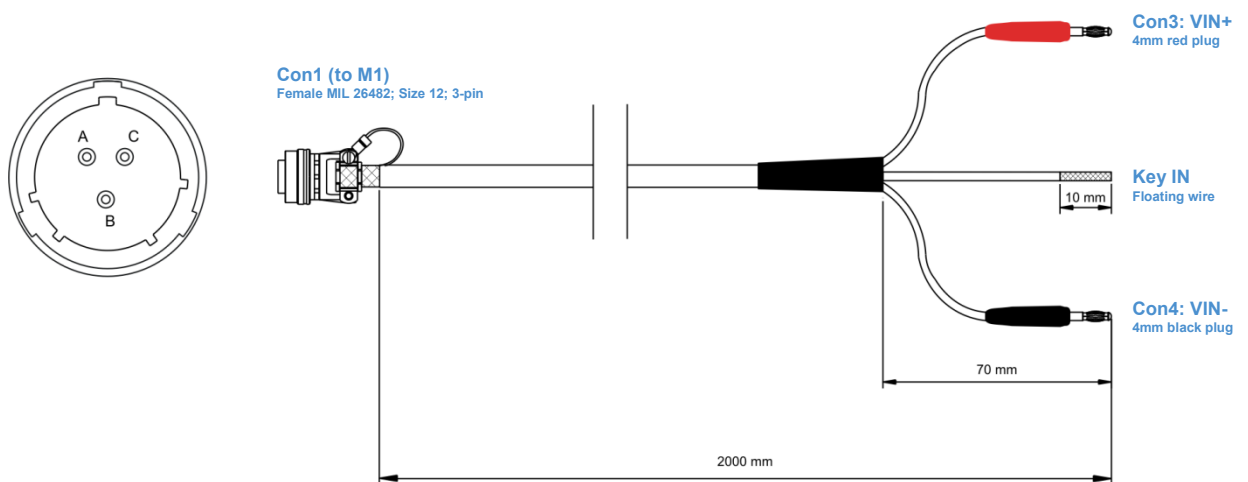

Con1	Signal
A	VIN+ (Con3; Red)
B	Key IN
C	VIN- (Con4; Black)



**E14-10-10-00**

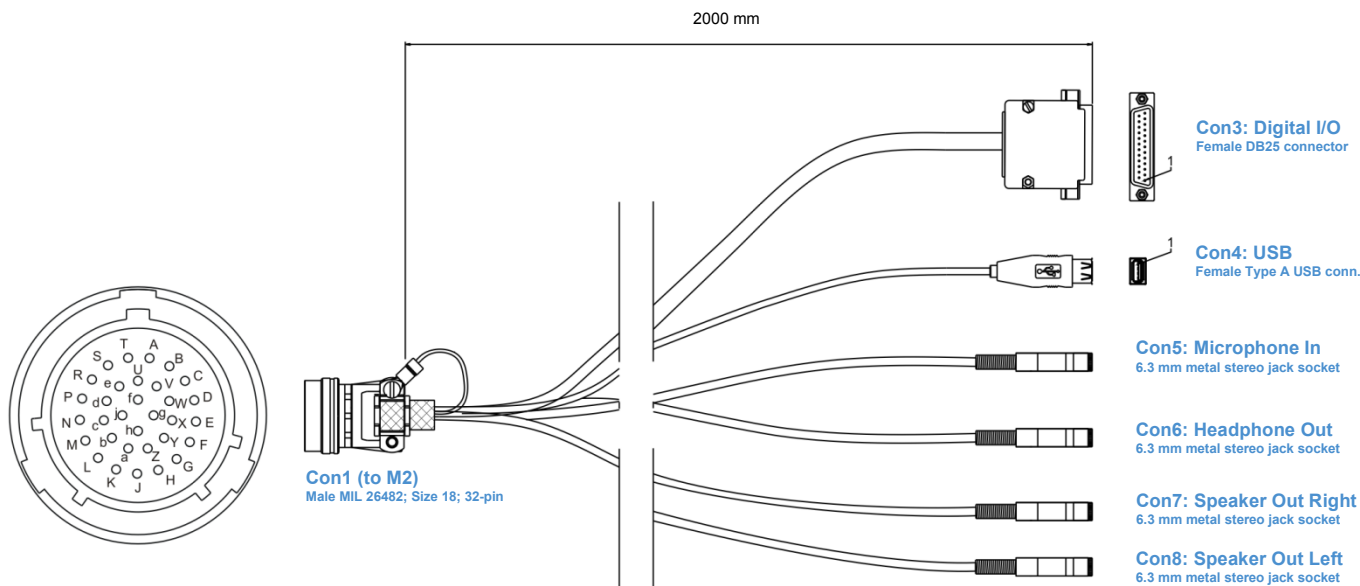

Con1	Digital I/O (Con3)	USB (Con4)	MIC In (Con5)	Headphone Out (Con6)	SPK Out R (Con7)	SPK Out L (Con8)	Signal
A	1						DIN1
B	2						DIN2
C	3						DIN3
D	4						DIN4
E	5						DIN5
F	6						DIN6
G	7						DIN7
H	8						DIN8
J	9						DIN9
K	10						DIN10
L	11						DIN_GND
M	22						DOUT_GND
N	17						DOUT1
P	18						DOUT2
R	19						DOUT3
S	20						DOUT4
T	21						DOUT5
U			Left				MIC_IN_L
V			Right				MIC_IN_R
W				Left			HP_OUTL
X				Right			HP_OUTR
Y					Left		ROUT+
Z					Right		ROUT-
a						Left	LOUT+
b						Right	LOUT-
c	12						ODOM+
d	13						ODOM-
e			GND	GND			GND
f		1					USB_+5
g		3					USB_D+
h		2					USB_D-
j		4					USB_GND

E14-21-10-00

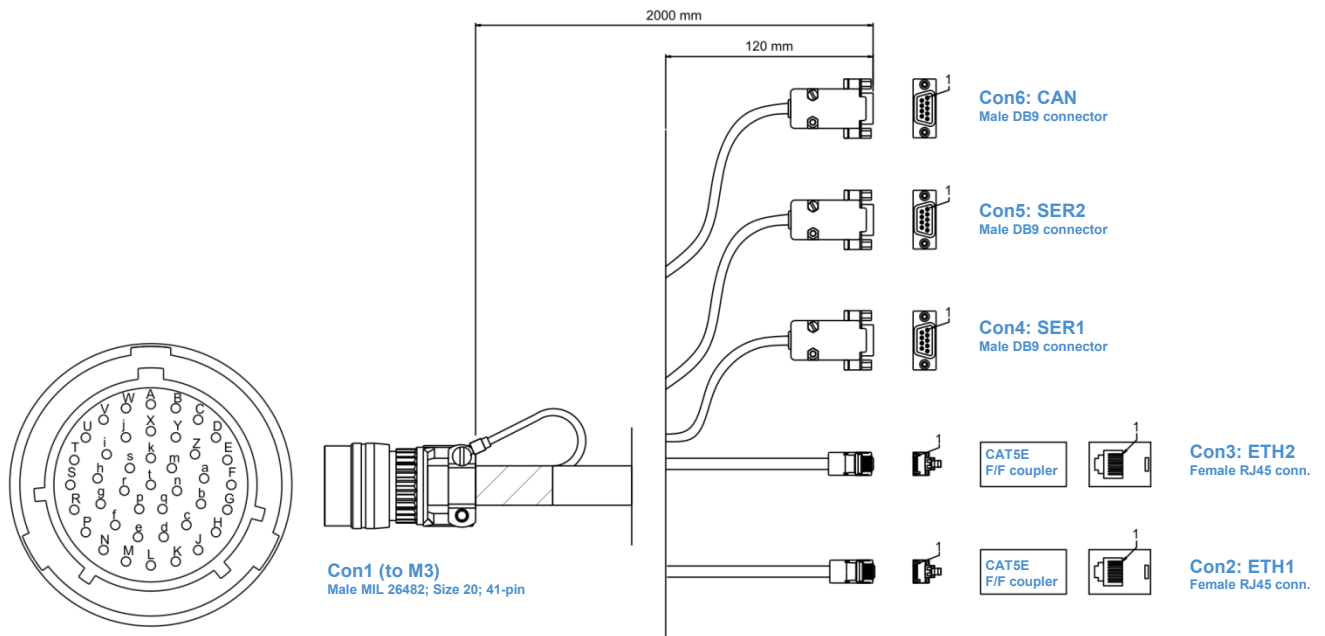

Con1	Con2: ETH1	Con3: ETH2	Con4: COM1	Con5: COM2	Con6: CAN	Signal	Con1	Con2: ETH1	Con3: ETH2	Con4: COM1	Con5: COM2	Con6: CAN	Signal
A	7					ETH1 RX2+	Y			7			RTS1
B	8					ETH1 RX2-	Z			8			CTS1
C	4					ETH1 TX2+	a			9			RI1
D	5					ETH1 TX2-	b			4			DTR1
E	3					ETH1 RX1+	c			3			TXD1
F	6					ETH1 RX1-	d			2			RXD1
G	1					ETH1 TX1+	e			1			DCD1
H	2					ETH1 TX1-	f			5			GND ISO
J		7				ETH2 RX2+	g				6		DSR2
K		8				ETH2 RX2-	h				7		RTS2
L		4				ETH2 TX2+	i				8		CTS2
M		5				ETH2 TX2-	j				9		RI2
N		3				ETH2 RX1+	k				4		DTR2
P		6				ETH2 RX1-	m				3		TXD2
R		1				ETH2 TX1+	n				2		RXD2
S		2				ETH2 TX1-	p				1		DCD2
T						Reserved	q				5		GND ISO
U						Reserved	r					7	CAN_P
V						Reserved	s					2	CAN_N
W						Reserved	t					3	GND_CAN
X			6			DSR1							

## Cables for the front panel maintenance interfaces

The following external cables are available as option:

- **703312001SL:** Cable for connecting Maintenance USB ports 1 and 2, and the Maintenance RS232 serial port – to MA1 connector
- **703310001SL:** Cable for connecting the Maintenance VGA output – to MA2 connector

### 703312001SL

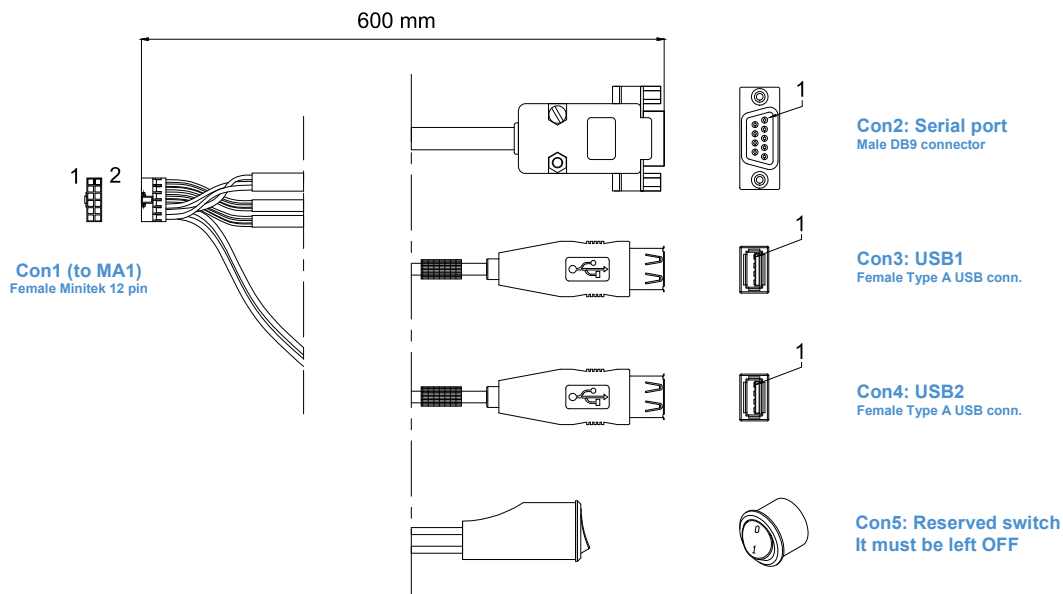

Con1	Con2: Serial port	Con3: USB1	Con4: USB2	Con5: Switch	Signal
1			1		USB2 +5V
2		1			USB1 +5V
3			2		USB2 Data +
4		2			USB1 Data +
5			3		USB2 Data -
6		3			USB1 Data -
7			4		USB2 GND
8		4			USB1 GND
9	3				TX
10	2				RX
11	5			1	GND
12				2	Reserved

**703310001SL**

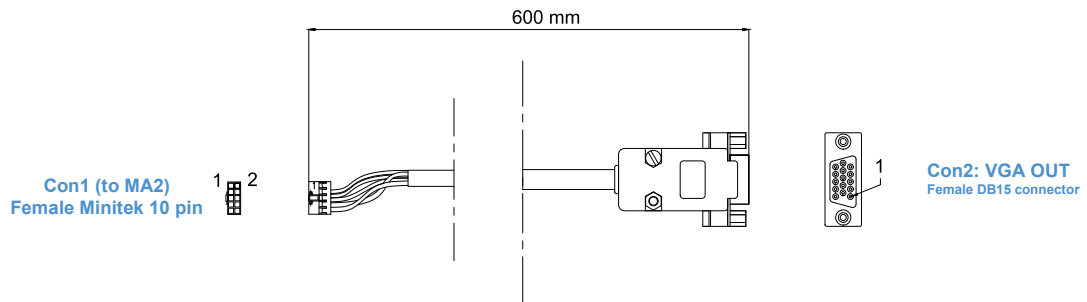

Con1	Con2: VGA OUT	Signal
1	3	BLUE
2	2	GREEN
3	1	RED
4	-	N.C.
5	6 / 7 / 8	GND
6	-	N.C.
7	13	HSYNC
8	15	SCL
9	14	VSYNC
10	12	SDA



## WORLD SUPPORT

### HEADQUARTERS

EUROTECH  
Via Fratelli Solari, 3/a  
33020 Amaro (UD) – Italy  
Tel: +39 0433.485.411  
Fax: +39 0433.485.499  
E-mail: support.it@eurotech.com  
Web: www.eurotech.com

### EUROPE

#### ITALY

EUROTECH  
Tel: +39 0433.485.411  
Fax: +39 0433.485.499  
E-mail: sales.it@eurotech.com  
E-mail: support.it@eurotech.com  
Web: www.eurotech.com

#### UNITED KINGDOM

EUROTECH  
Tel: +44 (0) 1223.403410  
Fax: +44 (0) 1223.410457  
E-mail: sales.uk@eurotech.com  
E-mail: support.uk@eurotech.com  
Web: www.eurotech.com

#### FRANCE

EUROTECH  
Tel: +33 04.72.89.00.90  
Fax: +33 04.78.70.08.24  
E-mail: sales.fr@eurotech.com  
E-mail: support.fr@eurotech.com  
Web: www.eurotech.com

### AMERICAS

#### USA

EUROTECH  
Toll free: +1 888.941.2224  
Tel: +1 301.490.4007  
Fax: +1 301.490.4582  
E-mail: sales.us@eurotech.com  
E-mail: support.us@eurotech.com  
Web: www.eurotech-inc.com

#### PARVUS

Tel: +1 800.483.1533  
Fax: +1 801.483.1523  
E-mail: sales@parvus.com  
E-mail: tsupport@parvus.com  
Web: www.parvus.com

### ASIA

#### JAPAN

ADVANET  
Tel: +81 86.245.2861  
Fax: +81 86.245.2860  
E-mail: sales@advanet.jp  
E-mail: tsupport@advanet.jp  
Web: www.advantec.co.jp

#### INDIA

EUROTECH  
Tel: +91 80.43.35.71.17  
E-mail: sales.in@eurotech.com  
E-mail: support.in@eurotech.com  
Web: www.eurotech.com

For your local contact please refer to: [www.eurotech.com/contacts](http://www.eurotech.com/contacts)