

VULCAN

Industrial Compact
Enclosure (ICE)
Technical Manual



Definitions

Arcom is the trading name for Arcom Control Systems Inc and Arcom Control Systems Ltd.

This product was known as the MERCURY until 30th June 2005. The internal (numeric) product codes used to identify this product and its variants have not changed. Please contact our sales team if you have any questions (see page 18).

Disclaimer

The information in this manual has been carefully checked and is believed to be accurate. Arcom assumes no responsibility for any infringements of patents or other rights of third parties, which may result from its use.

Arcom assumes no responsibility for any inaccuracies that may be contained in this document. Arcom makes no commitment to update or keep current the information contained in this manual.

Arcom reserves the right to make improvements to this document and /or product at any time and without notice.

Warranty

This product is supplied with a 3 year limited warranty. The product warranty covers failure of any Arcom manufactured product caused by manufacturing defects. The warranty on all third party manufactured products utilized by Arcom is limited to 1 year. Arcom will make all reasonable effort to repair the product or replace it with an identical variant. Arcom reserves the right to replace the returned product with an alternative variant or an equivalent fit, form and functional product. Delivery charges will apply to all returned products. Please check www.arcom.com/support for information about Product Return Forms.

Trademarks

ARM and StrongARM are registered trademarks of ARM Ltd.

Intel and XScale are trademarks or registered trademarks of Intel Corporation or its subsidiaries in the United States and other countries.

Windows CE .NET is a trademark of the Microsoft Corporation.

CompactFlash is the registered trademark of SanDisk Corp.

Linux is a registered trademark of Linus Torvalds.

RedBoot and Red Hat™ are registered trademarks of Red Hat Inc.

VxWorks is a registered trademark of Wind River.

Bluetooth is a registered trademark of Bluetooth SIG, Inc.

All other trademarks recognized.

Revision History

<i>Manual</i>	<i>PCB</i>	<i>Date</i>	<i>Comments</i>
Issue A		11 th June 2004	First full release of manual.
Issue B		6 th September 2004	ICE and COMMs cable modifications.
Issue C		16 th May 2005	Updated to reflect product name change.

© 2006 Arcom.

Arcom is a subsidiary of Eurotech Group.

www.eurotech.com

For contact details, see page 18.



Arcom operates a company-wide quality management system, which has been certified by the British Standards Institution (BSI) as compliant with ISO9001:2000

Contents

Introduction	4
VULCAN ICE 'at a glance'	5
Handling your board safely	6
About this manual	7
Related documents	7
Conventions	7
Overview of the VULCAN ICE ports	8
Connector details	9
Communication ports	9
USB 2.0 ports	11
Ethernet (10/100Base-T) ports	12
Digital I/O port	13
Additional I/O break out	14
Mounting details	15
Front panel dimensions	15
Back panel dimensions	16
Left hand side panel dimensions	16
Right hand side panel dimensions	17
Appendix A – Contacting Arcom	18
Appendix B – Specification	19
Index	20

Introduction

The VULCAN ICE provides a comprehensive enclosure solution for Arcom's VULCAN single board computer. The enclosure can be configured to suit a complete range of embedded applications with options.

The VULCAN ICE is fully CE compliant and is intended for use with all variants of the VULCAN board.

The enclosure contains a VULCAN single board computer with suitable break outs. It includes the following:

- Power input for +5V DC input.
- 3 RS232 serial ports (D type 9-way plugs).
- 1 RS422/485 serial port (D type 9-way plug).
- 1 digital I/O port (D type 25-way socket).
- 2 RJ45 Ethernet ports (10/100Base-T).
- 2 USB 2.0 type A ports.
- Reset button.
- CF+ socket break out.
- Expansion space for a PC/104 card with 2 additional I/O break outs.



This product was known as the MERCURY until 30th June 2005. The internal (numeric) product codes used to identify this product and its variants have not changed. Please contact our sales team if you have any questions (see page [18](#)).

VULCAN ICE 'at a glance'

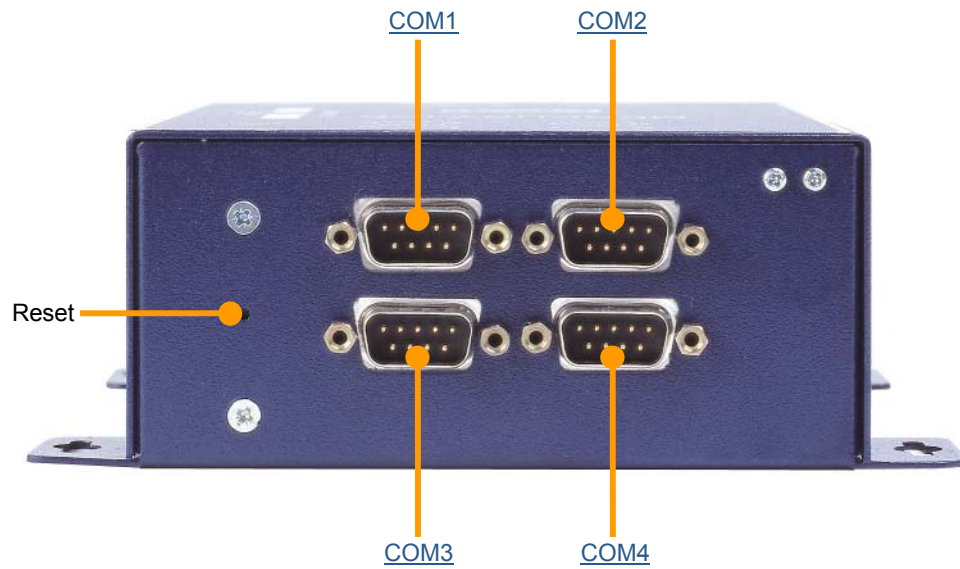
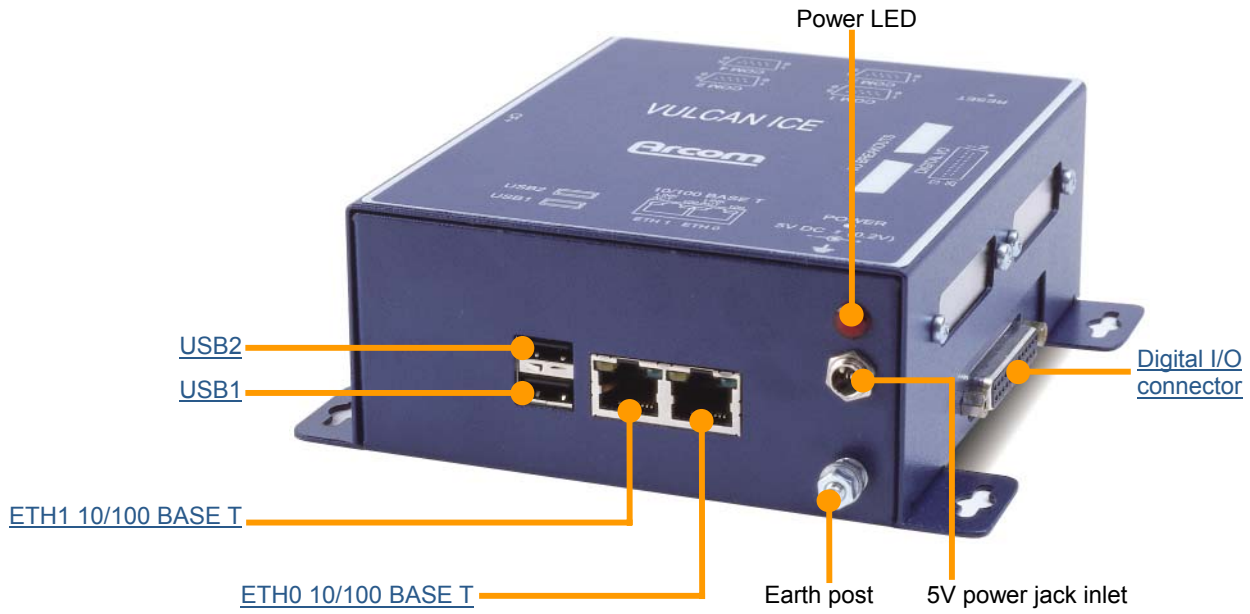

Handling your board safely

Anti-static handling

The VULCAN fitted inside the VULCAN ICE contains CMOS devices. These could be damaged in the event of static electricity being discharged through them. At all times, please observe anti-static precautions when handling circuit boards. This includes storing boards in appropriate anti-static packaging and wearing a wrist strap when handling.

Packaging

Should a board need to be returned to Arcom, please ensure that it is adequately packed, preferably in the original packing material.

About this manual

This manual describes the Industrial Compact Enclosure (ICE) and related interconnections.





Related documents

The VULCAN ICE Technical Manual is normally supplied as part of the VULCAN Development Kit, which also includes the VULCAN Technical Manual and the Arcom Embedded Linux Quickstart Manual. Other manuals are referred to from time to time. These are provided on the CD-ROM that accompanies your Development Kit.

Conventions

Symbols

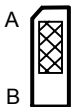
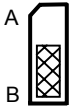
The following symbols are used in this guide:

Symbol	Explanation
	Note - information that requires your attention.
	Tip - a handy hint that may provide a useful alternative or save time.
	Caution – proceeding with a course of action may damage your equipment or result in loss of data.
	Jumper fitted on pin A.
	Jumper fitted on pin B.
	Jumper is fitted.
	Jumper is not fitted.

Overview of the VULCAN ICE ports

The VULCAN ICE has a number of ports. These are described below:

Power input jack	The VULCAN enclosure requires a 5V supply. This is connected via a 2.1mm jack. The typical current consumption is 700mA (VULCAN board only).
Ethernet	Two RJ45 Ethernet ports (10/100Base-T): <ul style="list-style-type: none">• 'LINK/ACT' yellow LED flashes when there is Ethernet traffic.• '100' green LED comes on when a 100Base-T connection is made.
USB 2.0	2 A type USB2.0 ports.
COM1	9-way D type break out for COM1 (RS232).
COM2	9-way D type break out for COM2 (RS232).
COM3	9-way D type break out for COM3 (RS232).
COM4	9-way D type break out for COM4 (RS485/RS422).
Digital I/O	25-way D type break out for TTL digital I/O.
CF+	Break out for CF+ socket.
Spare I/O	It is possible to fit one PC/104 module in the VULCAN enclosure. Two spare locations are included to allow the module to be broken out. These locations are fitted with blanking plates as standard.

Connector details

This section describes the connectors that are included with the VULCAN ICE.

Communication ports

The following tables show the generic conversion from the 40-way box header connector on the VULCAN to the four 9-way D connectors that appear on the outside of the ICE.

Communication port 1 (RS232)

J7 - VULCAN 40-way box header	Signal name	9-way D type plug
	N/C	1
33	Receive data (RX)	2
35	Transmit data (TX)	3
	N/C	4
39	Ground	5
	N/C	6
34	Request To Send (RTS)	7
36	Clear To Send (CTS)	8
	N/C	9

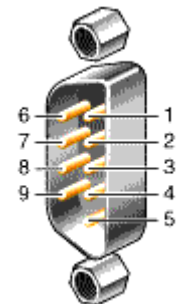

Communication port 2 (RS232)

J7 - VULCAN 40-way box header	Signal name	9-way D type plug
	N/C	1
13	Receive data (RX)	2
15	Transmit data (TX)	3
	N/C	4
17	Ground	5
	N/C	6
14	Request To Send (RTS)	7
16	Clear To Send (CTS)	8
	N/C	9

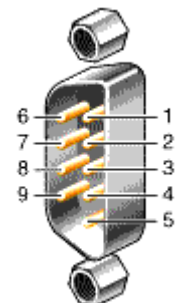

Communication port 3 (RS232)

J7 - VULCAN 40-way box header	Signal name	9-way D type plug
21	Data Carrier Detect (DCD)	1
23	Receive data (RX)	2
25	Transmit data (TX)	3
27	Data Terminal Ready (DTR)	4
29	Ground	5
22	Data Set Ready (DSR)	6
24	Request To Send (RTS)	7
26	Clear To Send (CTS)	8
28	Ring Indicator (RI)	9



Communication port 4 (RS485/RS422)

J7 - VULCAN 40-way box header	Signal name	9-way D type plug
	N/C	1
	N/C	2
5	RX/TX+	3
7	RX+	4
9	Ground	5
	N/C	6
6	RX/TX-	7
8	RX-	8
	N/C	9

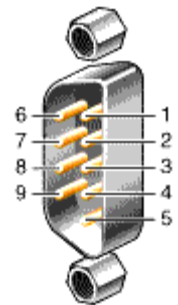

USB 2.0 ports

USB 2.0 uses the dual stacked USB A type receptacle.

The connector is fitted directly to the VULCAN board. Pin assignments are shown in the following table:

USB1	Signal name	USB2	Signal name
1	VBUS1	1'	VBUS2
2	D1-	2'	D2-
3	D1+	3'	D2+
4	GND	4'	GND

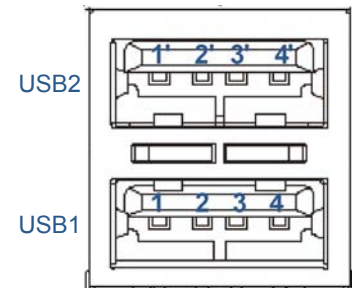

Ethernet (10/100Base-T) ports

Ethernet ports use dual shielded RJ45 connectors with LEDs. The connector is fitted directly to the VULCAN board. Pin assignment is shown in the following table:

ETH0	Signal name	ETH1	Signal name
1B	TX0+	1A	TX1+
2B	TX0-	2A	TX1-
3B	RX0+	3A	RX1+
4B	N/C	4A	N/C
5B	N/C	5A	N/C
6B	RX0-	6A	RX1-
7B	N/C	7A	N/C
8B	N/C	8A	N/C

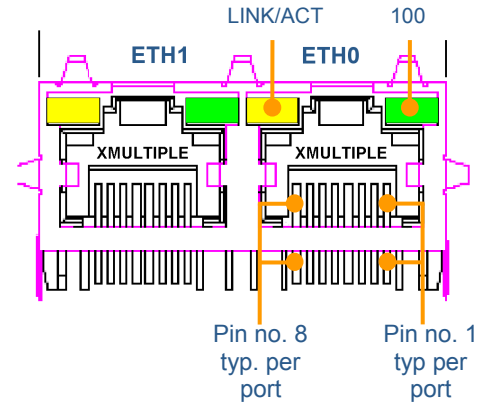

Digital I/O port

The following table shows the generic conversion from the 20-way header connector on the VULCAN to the 25-way D connector on the outside of the ICE:

J3 - VULCAN 20-way header	Signal name	25-way D type
1	+5V	1
2	+5V	14
3	IN0	2
4	IN1	15
5	IN2	3
6	IN3	16
7	IN4	4
8	IN5	17
9	IN6	5
10	IN7	18
11	GND	6
12	GND	19
13	OUT0	7
14	OUT1	20
15	OUT2	8
16	OUT3	21
17	OUT4	9
18	OUT5	22
19	OUT6	10
20	OUT7	23
	N/C	11
	N/C	24
	N/C	12
	N/C	25
	N/C	13

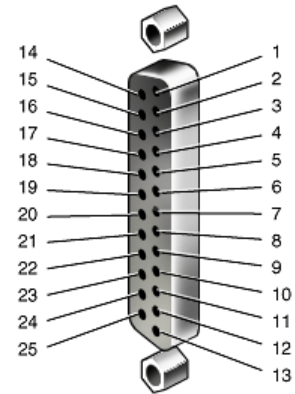

Additional I/O break out

The ICE can be fitted with one PC104 I/O card designed to be broken out through the rear of the enclosure. Refer to the following table, which shows the generic conversion from the 50-way IDC connector to the two 25-way D connectors that appear on the outside of the ICE:

50-way IDC pin number	25-way pin number [B]	25-way pin number [A]	50-way IDC pin number	25-way pin number [B]	25-way pin number [A]
1	1		26		1
2	14		27		14
3	2		28		2
4	15		29		15
5	3		30		3
6	16		31		16
7	4		32		4
8	17		33		17
9	5		34		5
10	18		35		18
11	6		36		6
12	19		37		19
13	7		38		7
14	20		39		20
15	8		40		8
16	21		41		21
17	9		42		9
18	22		43		22
19	10		44		10
20	23		45		23
21	11		46		11
22	24		47		24
23	12		48		12
24	25		49		25
25	13		50		13

Mounting details

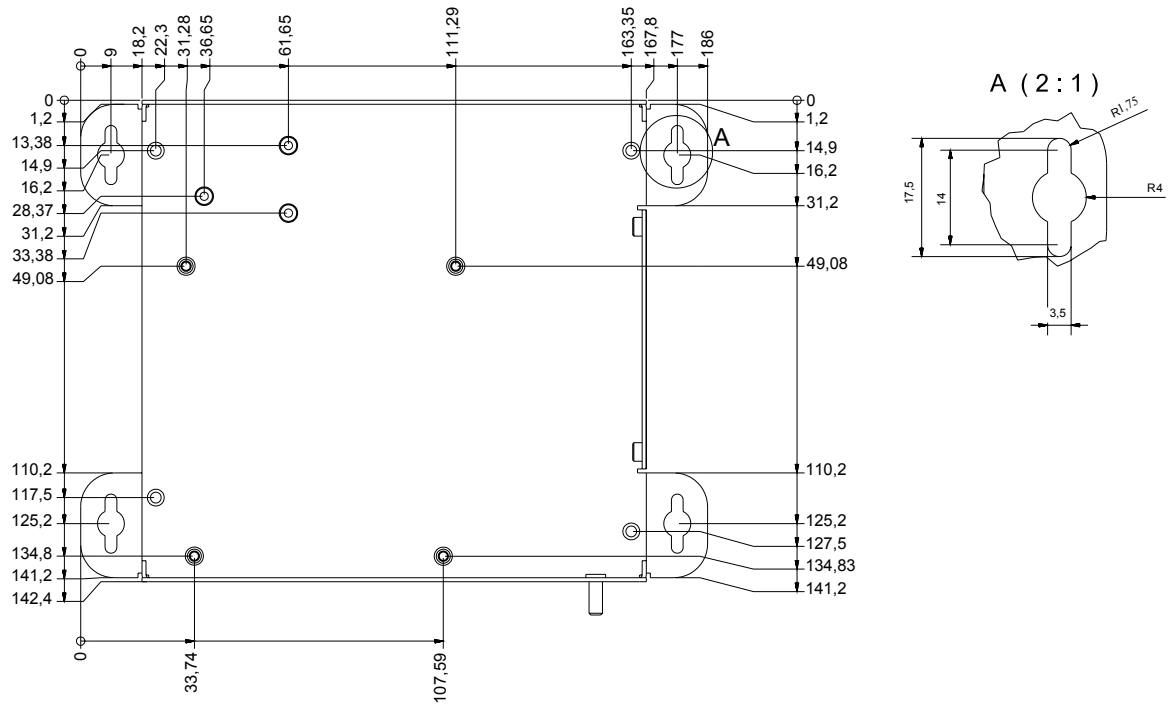

Front panel dimensions

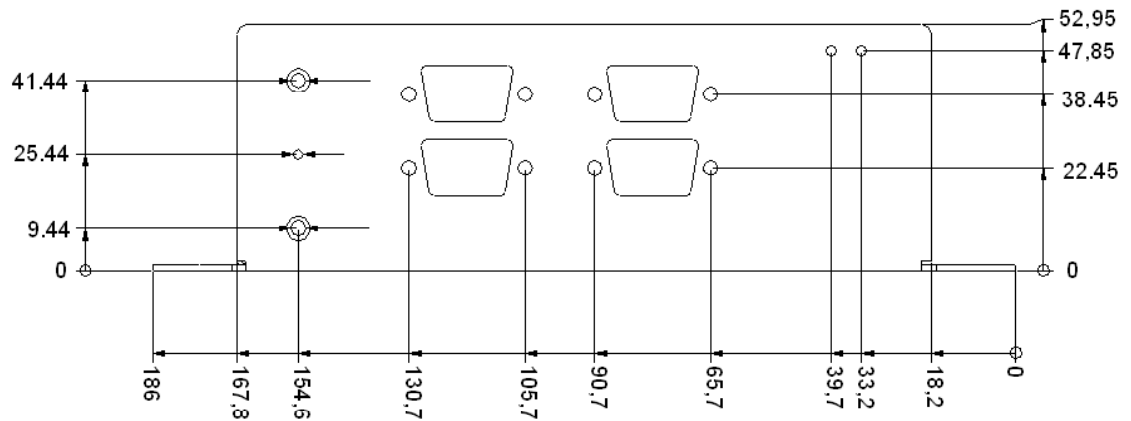

All dimensions in mm.

Back panel dimensions

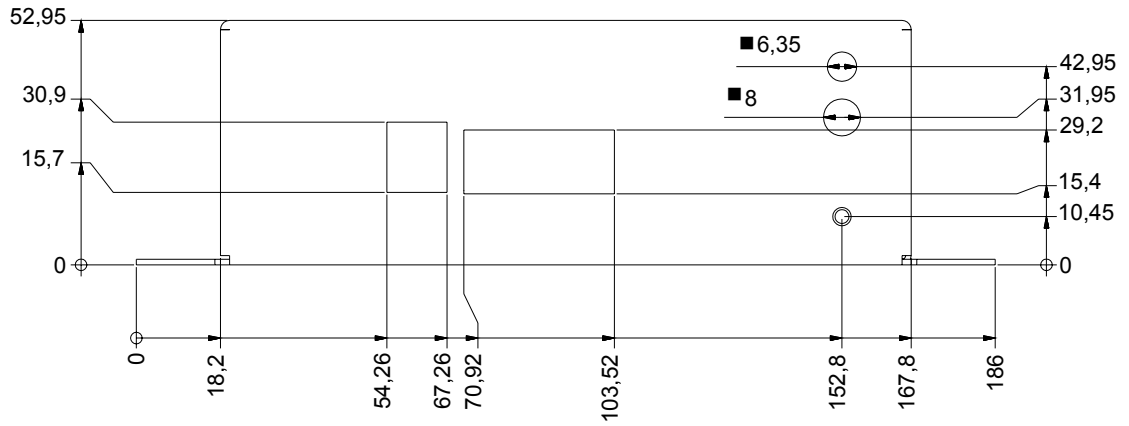

Left hand side panel dimensions

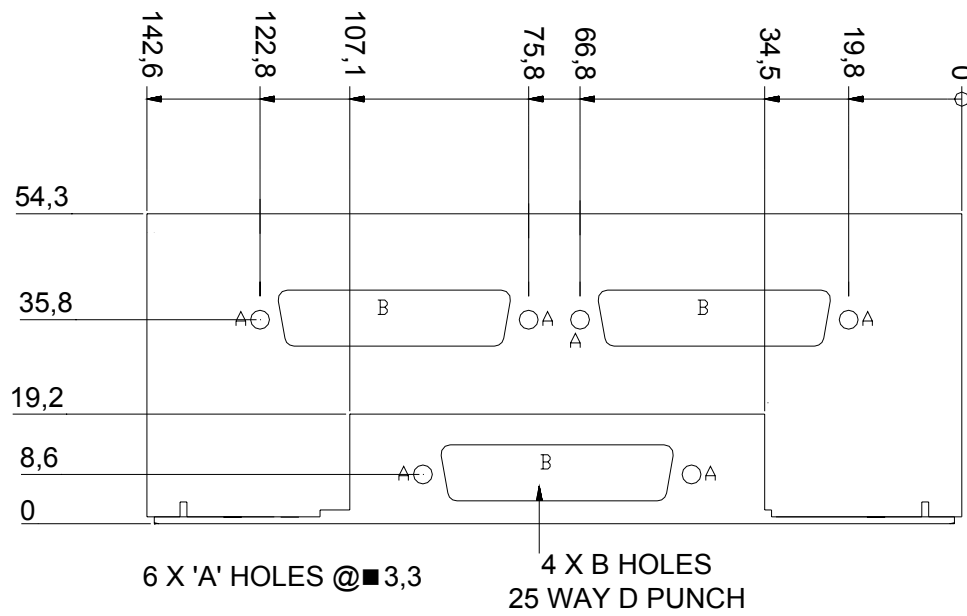

All dimensions in mm.

Right hand side panel dimensions

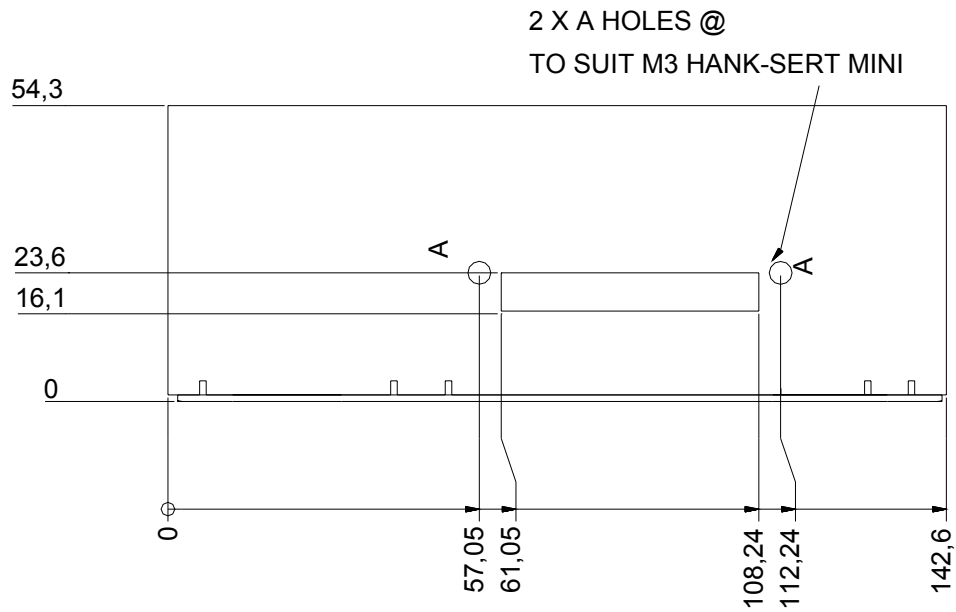

All dimensions in mm.



The size of the ICE will be increased on the next version of the enclosure. Contact the Arcom Sale team for further details.

Appendix A – Contacting Arcom

Arcom sales

Arcom's sales team is always available to assist you in choosing the board that best meets your requirements. Contact your local sales office or hotline.

Sales office US

Arcom
7500W 161st Street
Overland Park
Kansas
66085
USA

Tel: 913 549 1000

Fax: 913 549 1002

E-mail: us-sales@arcom.com

Sales office UK

Arcom
Clifton Road
Cambridge
CB1 7EA
UK

Tel: 01223 411 200

Fax: 01223 410 457

E-mail: sales@arcom.co.uk

Comprehensive information about our products is available from our web sites:
www.arcom.com and www.arcom.co.uk.



While Arcom's sales team can assist you in making your decision, the final choice of boards or systems is solely and wholly the responsibility of the buyer. Arcom's entire liability in respect of the boards or systems is as set out in Arcom's standard terms and conditions of sale. If you intend to write your own low level software, you can start with the source code on the disk supplied. This is example code only to illustrate use on Arcom's products. It has not been commercially tested. No warranty is made in respect of this code and Arcom shall incur no liability whatsoever or howsoever arising from any use made of the code.

Technical support

Arcom has a team of technical support engineers available to provide a quick *and free* response to your technical queries.

Technical support US

Tel: 913 549 1010

Fax: 913 549 1001

E-mail: us-support@arcom.com

Technical support UK

Tel: +44 (0)1223 412 428

Fax: +44 (0)1223 403 409

E-mail: euro-support@arcom.com

Appendix B – Specification

Power	4.5W maximum (VULCAN board only)
Input voltage	5V DC \pm 5%
Temperature	Operating: -20° (-4°F) to +60° C (140°F) Storage: -20° (-4°F) to +85° C (185°F)
Humidity	10% to 90% RH (non-condensing)
Dimensions	Enclosure body: 120.75 x 142.6 x 53mm. Enclosure including mounting feet: 154 x 142.6 x 53mm.

Index

9

9-way connector · 9

A

anti-static · 6

B

back panel · 16
box header connector · 9
break outs · 4, 8

C

CF+ · 4, 8
code, source · 18
COM1 · 8
COM2 · 8
COM3 · 8
COM4 · 8
communication port
 1 · 9
 2 · 9
 3 · 10
 4 · 10
components · 4
connectors · 9
 9-way · 9
 box header · 9
 D · 9
 RJ45 · 12
contact details · 18
conversion · 9
current · 8

D

D connectors · 9
digital I/O · 4, 8
 port · 13
dimensions · 19
 back panel · 16
 front panel · 15
 left panel · 16
 right panel · 17

E

electromagnetic compatibility · 6
EMC · 6
ethernet ports · 4, 8, 12

F

front panel · 15

H

humidity · 19

I

I/O · 4, 8
input, power · 4

K

key · 7

L

left panel · 16

M

mounting · 15
MTBF · 19

P

panel
 back · 16
 front · 15
 left · 16
 right · 17
PC/104 · 4
ports
 digital I/O · 13
 ethernet · 4, 8, 12
 power input · 8
 serial · 4
 spare · 8
 USB · 4, 8, 11

power · 19
 consumption · 8
 input · 4, 8
products · 18

R

reset · 4
right panel · 17
RJ45 · 8, 12
RS232 · 9, 10
RS422 · 10
RS485 · 10

S

sales · 18
serial ports · 4
source code · 18
spare ports · 8
specification · 19
static · 6
support, technical · 18
symbols · 7

T

technical support · 18
temperature · 19

U

USB ports · 4, 8, 11

V

voltage · 19

W

weight · 19